

Note: Due to this being copy-pasted off the website and having all of its HTML elements removed the formatting may not always be great. My apologies about that. Other than that it should all mostly check out.

1: (Q694) The main input data to the Stall Warning Annunciator System are: 1. Mach Meter indication. 2. Angle of Attack. 3. Indicated Airspeed (IAS). 4. Aircraft configuration (Flaps/Slats).

The combination regrouping all the correct statements is:

- A: 2, 4.
- o B: 1, 2.
- o C: 2, 3.

2: (Q404) Automatic flight systems may be capable of controlling the aircraft flight in:

- A: azimuth, elevation and velocity.
- o B: azimuth and elevation only.
- o C: azimuth and velocity only.

3: (Q608) In An Air Data Computer (ADC), aeroplane altitude is calculated from:

- o A: The difference between absolute and dynamic pressure at the fuselage.
- o B: Measurement of elapsed time for a radio signal transmitted to the ground surface and back.
- C: Measurement of absolute barometric pressure from a static source on the fuselage.

4: (Q354) Cabin chemical oxygen generators are located in?

- o A: The overhead bins.
- B: The passenger service units.
- o C: The cargo hold.

5: (Q206) Who controls the 'no smoking' and 'fasten seat belts' lights?

- A: Pilot.
- o B: Passenger.
- o C: Flight attendant.

6: (Q364) Where can you find a direct reading pressure gauge on an oxygen system?

- A: On the oxygen bottle.
- o B: On the oxygen system control panel.
- o C: On the flight deck.

7: (Q25) Aerodynamic speeds vary all the way from low subsonic to hypersonic. The limits of supersonic speed range are

- o A: 0.8 to 1.2 M
- B: 1.2 to 5 M
- o C: 0.3 to 0.8 M

8: (Q696) The input to a basic stall warning system is:

- o A: IAS.
- B: Angle of attack.
- o C: Slat/flap position.

9: (Q218) An air-to-air heat exchanger is provided to....

- A: reduce the air supply temperature.
  - o B: provide an emergency ram air supply.
  - o C: increase the air supply temperature.
- 10: (Q420) Automatic mach trim is functional in the....
- o A: pitch and roll channel with the autopilot engaged.
  - o B: pitch channel only with the autopilot disengaged.
  - C: pitch channel only with the autopilot engaged.
- 11: (Q22) To which flight control are wing spoilers, when used asymmetrically, associated?
- o A: rudder.
  - B: ailerons.
  - o C: elevators.
- 12: (Q384) A three-axis auto pilot is....
- A: an auto stabilisation system.
  - o B: a system which will maintain a preselected altitude.
  - o C: a system which will maintain a preselected airspeed.
- 13: (Q470) What is the correct response to a TCAS RA?
- o A: Pilots have to follow ATC instructions as these override TCAS RA's.
  - B: Pilots follow the climb or descent commands smoothly and immediately.
  - o C: Pilots turn 90° and they follow the climb or descent commands smoothly and immediately.
- 14: (Q173) What is the output speed of a constant speed drive?
- o A: 12000rpm
  - o B: Variable speed depending on engine speed.
  - C: 6000rpm
- 15: (Q735) Which network system routes data between the airplane and ground networks and stores airline data and applications?
- A: IMA (core network).
  - o B: ATIS.
  - o C: IDN.
- 16: (Q182) What is the function of the flyweight governor (installed in the RAT)?
- A: It controls the speed of the ram air turbine.
  - o B: It controls the output voltage of the hydraulic motor generator (HMG).
  - o C: It controls the speed of the constant speed motor generator (CSM/G).
- 17: (Q360) When the N/100% selector is placed in the 'N' position on a diluter demand regulator, what is the oxygen flow supplied?
- o A: 100% oxygen while the user is inhaling.
  - B: A mixture of oxygen and cabin air while the user is inhaling.
  - o C: A mixture of oxygen and cabin air at a constant flow.
- 18: (Q87) Compared to the other ionospheric layers at higher altitudes, the ionization density of the D layer is

- o A: about the same.
- B: relatively low.
- o C: relatively high.

19: (Q637) Using a classic Artificial horizon, the aircraft performs a right turn (during 1 minute) through 270° at a constant angle of bank and rate of turn. The indication is:

- A: Nose up, too much bank.
- o B: Bank and pitch correct.
- o C: Nose up, not enough bank.

20: (Q157) Which of the following combinations of satellite navigation systems provide the most accurate position fixes in air navigation?

- A: NAVSTAR/GPS and GLONASS.
- o B: NNSS-Transit and GLONASS.
- o C: GLONASS and COSPAS-SARSAT.

21: (Q93) Under certain conditions, such as ducting, line-of-sight radio waves often propagate for distances far beyond their normal ranges because of which of the following factors?

- A: temperature inversions.
- o B: low cloud masses.
- o C: ionospheric storms.

22: (Q372) How is pneumatic leak detection done?

- A: Pressure sensors.
- o B: Thermal switches.
- o C: Thermocouples.

23: (Q76) A stone dropped into water creates a series of expanding circles on the surface of the water. This is an example of which of the following types of wave motion?

- o A: Longitudinal.
- o B: Concentric.
- C: Transverse.

24: (Q296) Cross feed valves permit fuel transfer from ...

- o A: left tank to right tank.
- B: any tank to any engine.
- o C: tank to tank.

25: (Q765) Documentation (FCOM, MEL, AFM, CDL) is part of the ...

- o A: Avionics Domain.
- B: Flight Operations Domain.
- o C: Communication & Cabin Domain.

26: (Q647) On an instrument check whilst taxiing, when carrying out a turn, the ball on the turn and bank indicator should indicate:

- o A: a slip into the turn.
- B: a skid out of the turn.
- o C: no slip or skid.

27: (Q581) When an aircraft altimeter is set at 1013 mbar (29,92 inHg) on the ground, the altimeter will read

- o A: calibrated altitude.
- B: pressure altitude.
- o C: density altitude.

28: (Q329) What is the source of air for the windscreen pneumatic rain removal system?

- A: engine bleed air.
- o B: a dedicated pneumatic motor to drive windscreen wipers.
- o C: the venturi windscreen duct.

29: (Q297) How is the amount of Fuel indicated to the pilots?

- o A: Volume (m3)
- o B: Height (cm or inch)
- C: Weight (Kgs or Lbs)

30: (Q607) An Air Data Computer (ADC):

- o A: Is an auxiliary system that provides altitude information in the event that the static source is blocked.
- o B: Measures position error in the static system and transmits this information to ATC to provide correct altitude reporting.
- C: Transforms air data measurements into electric impulses driving servo motors in instruments.

31: (Q399) What is the controlling factor in the automatic flare mode?

- o A: Localizer signal.
- o B: Decision height.
- C: Radio altimeter.

32: (Q24) Aerodynamic speeds vary all the way from low subsonic to hypersonic. The limits of transonic speed range are

- o A: 0.3 to 0.8 M
- o B: 1.2 to 5 M
- C: 0.8 to 1.2 M

33: (Q532) In a Frise aileron control system....

- o A: the down-going aileron leading edge protrudes into the airflow.
- o B: the up-going aileron moves through a greater angle than the down going aileron.
- C: the up-going aileron produces increased drag.

34: (Q685) Mode available for (EFIS) HSI on some units are:

- o A: Airspeed and Mach.
- o B: VOR, ILS, MAP and AUTO TRIM.
- C: MAP and PLAN.

35: (Q239) In an airconditioning system, the purpose of the condenser is to condense water in the air before it goes to the....

- A: water extractor.

- o B: heat exchanger.
  - o C: bypass valve.
- 36: (Q609) When the moisture separator is purged in a pneumatic system, it dumps
- A: just the moisture trap.
  - o B: the whole system.
  - o C: the system between vacuum pump and regulator valve.
- 37: (Q432) The fixed trim tab....
- o A: is riveted to the leading edge.
  - B: is adjusted by bending.
  - o C: is manually controlled from the cockpit.
- 38: (Q457) Until touchdown, auto pilot, with auto-land system....
- A: remains engaged ready for G/A.
  - o B: disconnects after a short time.
  - o C: drives the throttles forward.
- 39: (Q347) Why is a hydraulic damper fitted to a nose wheel steering system?
- o A: to centralise the nose wheel during an up selection.
  - B: to reduce vibration and shimmy.
  - o C: To centralise the nose leg assembly during an up selection.
- 40: (Q214) The RAM air supply is used....
- A: as an emergency air source on pressurized aircraft to ventilate the cockpit and the cabin.
  - o B: only on unpressurized aircraft.
  - o C: as an alternate source to power the air-conditioning packs.
- 41: (Q273) What ensures that the agent (Halon 1211) is dispersed in the shortest time possible in a high rate discharge bottle?
- A: Nitrogen.
  - o B: Oxygen.
  - o C: Halon 1301 or Nitrogen.
- 42: (Q672) The flight data recorder must automatically stop data recording when the....
- A: the airplane is on the ground and the engines are turned off.
  - o B: main gear shock strut compresses when touching the runway.
  - o C: airplane clears the runway.
- 43: (Q176) In which type of unit can a permanent magnet generator (PMG) be found?
- o A: DC generator.
  - B: Brushless AC alternator.
  - o C: DC alternator.
- 44: (Q619) When climbing, the true airspeed....
- o A: remains the same.
  - o B: will decrease with a constant IAS.
  - C: will increase with constant IAS.

- 45: (Q405) An automatic flight control system is fitted with control wheel steering (CWS)
- o A: the CWS is only there for steering on the ground.
  - o B: the autopilot must be disengaged before the pilot can input manoeuvring commands.
  - C: manoeuvring commands may be input by applying normal force to the control yoke without first disengaging the autopilot.
- 46: (Q172) Which of the following systems does not use a constant speed drive?
- o A: Engine driven alternator.
  - o B: Integrated drive generator (IDG)
  - C: APU alternator.
- 47: (Q335) What does a green/grey spot marking on aircraft tyre casing represent?
- o A: Military reference.
  - o B: The light part of the tyre.
  - C: Leak holes.
- 48: (Q615) When OAT increases what happens to a helicopter operating ceiling?
- A: Decrease.
  - o B: Increase.
  - o C: No effect.
- 49: (Q676) What does a FDR record when combined with a CVR?    1. Cockpit voice;    2. Radio;    3. Public addresses from the cockpit;    4. Cabin voice
- o A: all 4.
  - B: 1, 2 and 3.
  - o C: 2 and 4.
- 50: (Q342) When the landing gear is locked up, the cockpit indicator shows ...
- A: no indication.
  - o B: green light.
  - o C: red light.
- 51: (Q523) An aircraft with two passenger decks with more than 100 seats per deck is equipped with....
- o A: 3 megaphones.
  - o B: 1 megaphone.
  - C: 4 megaphones.
- 52: (Q374) An automatic pilot is a system which can ensure the functions of:
- A: Piloting and guidance of an aircraft in both the horizontal and vertical planes.
  - o B: Navigation.
  - o C: Piloting from take-off to landing without any action from the pilot.
- 53: (Q481) Weather radar domes are protected from lightning strikes by
- A: bonding strips.
  - o B: special conducting or non-conducting grease.
  - o C: the use of special conductive paint.

54: (Q193) What provides overheat warning in a transformer rectifier unit?

- o A: Thermocouple.
- B: Thermal switch.
- o C: Voltage sensor.

55: (Q505) The continuous broadcast of recorded non-control information in busier terminal areas (i.e. Airport) is called

- A: ATIS
- o B: ACARS
- o C: SITA

56: (Q149) To carry out FMS database update on FMS

- o A: insert new data on CDU.
- B: use database loader.
- o C: insert new EPROM.

57: (Q19) A wing slat is a movable airfoil attached to the leading edge of high-performance airplane wings. What is their purpose?

- A: reduce stalling speed.
- o B: act as a dive brake or speed brake.
- o C: replace flaps.

58: (Q367) What is used to prevent moisture from freezing as the pressure drops in a pneumatic system?

- o A: There is no water or moisture in compressed air.
- B: A water separator and a desiccant is fitted which collects the moisture from the air.
- o C: An electrical heater is fitted which prevents the water from freezing.

59: (Q251) When operating the outflow valve in manual/emergency mode, which motor is used?

- o A: The AC motor.
- o B: Both AC and DC motors.
- C: The DC motor.

60: (Q30) An aircraft....

- A: has more than one critical mach number on different parts of the aircraft.
- o B: has only one critical mach number.
- o C: has more than one critical mach number on the wing only.

61: (Q490) For most radio altimeters, when a system error occurs during approach the

- A: Height indication is removed.
- o B: DH lamp flashes red.
- o C: DH lamp flashes red and the audio signal sounds.

62: (Q774) All the last generation aircraft use flight control systems. The FMS is the most advanced system. It can be defined as a....

- A: 3-axis Flight Management System.
- o B: 2-axis Flight Management System.
- o C: management system optimized in the horizontal plane.

63: (Q31) The angle of attack of a blade is the

- o A: angle between the aircraft longitudinal axis and relative air flow.
- B: angle between the chord line and relative airflow.
- o C: angle between the chord line and plane of rotation.

64: (Q429) LNAV is an ...(1)..... input to the.....(2)..... channel using data from the ...(3).....

- o A: (1) outer loop - (2) pitch - (3) FMC
- B: (1) outer loop - (2) roll - (3) FMC
- o C: (1) inner loop - (2) pitch - (3) ADC

65: (Q140) The IRS position can be initialized....

- o A: at designated positions en-route and on the ground.
- o B: on the ground and in flight with VOR/DME.
- C: on the ground only.

66: (Q377) To carry out an autopilot check first

- o A: switch on NAV receivers.
- o B: switch off all power.
- C: ensure all control surfaces are unobstructed.

67: (Q626) In transport category airplanes, the temperatures are generally measured with: 1. resistance thermometers. 2. thermocouple thermometers. 3. reactance thermometers. 4. capacitance thermometers. 5. mercury thermometers. The combination regrouping all the correct statements is:

- o A: 1,3,4,5
- o B: 1,2,5
- C: 1, 2.

68: (Q23) With respect to flight spoilers, when do they operate?

- o A: only operate in flight.
- B: can operate both on the ground and in flight.
- o C: only operate on the ground.

69: (Q550) What are ground spoilers used for?

- o A: To assist the aircraft when go around is selected on ground.
- o B: For steering commands while taxiing.
- C: To dump lift.

70: (Q468) The ATC altitude information is relative to....

- A: 1013.2 mbar level.
- o B: 29.92 bar level.
- o C: 10.92 mbar level.

71: (Q727) Communication in the integrated modular avionics network is partly standardized in...

- A: ARINC 429, ARINC 653 or AFDX.
- o B: ARINC 429 or AFDX (Avionics Full Duplex).
- o C: ARINC 653 for the software avionics and AFDX for the data network bus.

- 72: (Q538) Aircraft flight control trim systems must be designed and installed so that the....
- o A: operating control and the trim tab will always move in the same direction.
  - B: pilot can determine the relative position of the trimtab from the cockpit.
  - o C: trim system will disengage or become inoperative if the primary flight control system fails.

- 73: (Q224) The heat exchanger in a turbo-fan system is cooled by...
- o A: engine bleed air or blower air.
  - o B: air bled from the main cabin supply duct.
  - C: ambient ram air.

- 74: (Q8) In a Frise aileron control system....
- o A: the down-going aileron moves through a greater angle than the up- going aileron.
  - o B: the down-going aileron allows air to spill from below the wing to the upper surface of the ailerons.
  - C: the up-going aileron produces increased drag.

- 75: (Q57) What is a Fuselage body Station?
- o A: lateral point on the fuselage.
  - o B: lateral point on a wing.
  - C: longitudinal point on the fuselage.

- 76: (Q292) In a fuel system with interconnected vents ...
- A: the expansion space must be 2 % of the tank capacity.
  - o B: an expansion space is not required.
  - o C: the expansion space must be 10 % of the tank capacity.

- 77: (Q191) Which formula represents the transformer ratio?
- o A:  $V_2 \times V_1 = N_2 \times N_1$
  - o B:  $V_2 / N_2 = V_1 / N_1$
  - C:  $V_2 / V_1 = N_2 / N_1$

- 78: (Q265) A carbon monoxide detector has to be replaced.....
- o A: monthly.
  - B: normally every 90 days.
  - o C: daily.

- 79: (Q88) What two layers in the ionosphere recombine and largely disappear at night?
- o A: F1 and F2
  - B: D and E
  - o C: D and F

- 80: (Q485) A false indication of water may be given by the AWR display when:
- o A: flying over land with the Land/Sea switch in the Sea position.
  - B: flying over mountainous terrain.
  - o C: there is cloud and precipitation between the aircraft and a cloud target.

- 81: (Q159) The electrolyte in a NiCd battery is?

- o A: Acid based.
- B: Alkaline based.
- o C: Lithium based.

82: (Q94) A transmission line is designed to perform which of the following functions?

- o A: Disperse energy in all directions.
- B: Guide electrical energy from point to point.
- o C: Replace the antenna in a communications system.

83: (Q271) What class of fire can be extinguished with water?

- o A: All fire classes.
- B: Class A
- o C: Class D

84: (Q638) When turning (during 1 minute) through 90° at constant attitude and bank, a classic artificial horizon indicates:

- o A: Nose up and bank angle too high.
- o B: Nose up and correct angle of bank.
- C: Nose up and bank angle too low.

85: (Q18) What is the effect of a Fowler flap on the wing?

- o A: increases wing area only.
- o B: increases camber only.
- C: increases camber and wing area.

86: (Q80) Varying which of the following wave characteristics will cause the length of sound waves to vary?

- o A: Phase.
- B: Frequency.
- o C: Amplitude.

87: (Q611) A static port is used to measure:

- o A: dynamic pressure plus pitot pressure.
- o B: dynamic pressure minus pitot pressure.
- C: atmospheric pressure.

88: (Q245) What is the function of the positive pressure relief valves?

- o A: They control cabin pressure and ensure the cabin altitude does not go above 10.000 ft.
- B: They relieve excess cabin pressure.
- o C: They prevent negative cabin pressure differential.

89: (Q397) If go-around has been initiated after auto-land has been selected, the aeroplane will

- o A: rotate nose up.
- B: increase speed and rotate nose up.
- o C: increase speed.

90: (Q475) A 'TCAS II' (Traffic Collision Avoidance System) provides:

- o A: a simple intruding airplane proximity warning..

o B: the intruder relative position and possibly an indication of a collision avoidance manoeuvre within the horizontal plane only.

• C: the intruder relative position and possibly an indication of a collision avoidance manoeuvre within the vertical plane only.

91: (Q414) A dual-dual stability augmentation system:

• A: can survive the first failure and reverts to manual control in the event of a second failure.

o B: ensures that a lane failure results in that the actuators remains at their position when the failure occurred.

o C: disengages when a failure occurs and the system reverts to manual control.

92: (Q734) The core network system has ...

o A: an ethernet network and an crew information network.

o B: an open data network, an isolated data network and an avionics network.

• C: an open data network and an isolated data network.

93: (Q298) How is the fuel quantity measured in the manual way?

o A: The electrical resistance between two points.

• B: With dipstick.

o C: From the top of the wing visual.

94: (Q547) Spoilers are speed brakes. Where can other speed brakes be located?

o A: On the wing.

o B: Under the Fuselage.

• C: Rear of the Fuselage.

95: (Q594) If an aircraft were to climb after suffering a pitot blockage, the ASI would apparently:

o A: show no change at all.

o B: under-read, indicating a decrease in speed.

• C: over-read, indicating an increase in speed.

96: (Q625) If one probe of a multi-sensor T.G.T. system failed , the reading would:

o A: increase by 20 - 30 degrees C.

• B: be practically unaffected.

o C: fall to zero.

97: (Q304) What is the function of a thermal relief valve in an hydraulic system?

o A: prevent excess temperature.

• B: relieve excess pressure.

o C: prevent a leak back of pressure.

98: (Q729) An airborne Ethernet electrical cable (AFDX) is

• A: equipped with 4 pins Quadrx connectors.

o B: equipped with 8 pins RJ45 connectors.

o C: equipped with 4 pins RJ45 connectors.

99: (Q100) What is the wavelength of the basic Marconi antenna?

• A: 1/4 wavelength.

- o B: 1/2 wavelength.
- o C: wavelength.

100: (Q38) What prevents the rotor blades from 'folding up' during rotation?

- A: the centrifugal force.
- o B: the weight.
- o C: the lift force.

101: (Q345) Aquaplaning can be reduced by ...

- A: an anti-skid device.
- o B: increased flaring.
- o C: lowering slats.

102: (Q116) The Cockpit Voice Recorder (CVR) records : 1. conversations between pilot and co-pilot. 2. conversations between cockpit crew and air traffic controllers. 3. passenger announcements. 4. ambient cockpit sounds for example deployment of the landing gear.

- o A: 1, 2 and 3.
- o B: only 1 and 2.
- C: 1, 2, 3 and 4.

103: (Q732) The first 2 bytes of the IP address for IMA communication are called ...

- o A: Sign Status Matrix (SSM).
- B: the Net ID.
- o C: Host ID.

104: (Q310) How do you prevent hydraulic fluid foaming?

- o A: pass over a tray.
- B: by pressurising.
- o C: vent reservoir to atmosphere.

105: (Q133) Bearing information in an ADF system is....

- o A: received by the antenna.
- o B: provided by the flight management system.
- C: measured and calculated by the ADF system.

106: (Q492) The aircraft radio equipment which emits on a frequency of 4400 MHz is the:

- A: radio altimeter.
- o B: primary radar.
- o C: weather radar.

107: (Q680) This amber symbol appears in place of the normal altitude display when: (See the figure)



- o A: the selected radio altitude has been reached.
  - B: there is a failure of the radio altimeter.
  - o C: the radio altitude needs re-setting on the EHSI.
- 108: (Q11) Which flight control surfaces does have a Flaperon function?
- o A: flaps and speed brakes.
  - B: flaps and ailerons.
  - o C: flaps and elevators.
- 109: (Q108) The HF (high frequency) range of the radio spectrum is the band extending from
- o A: 30 MHz to 300 MHz.
  - o B: 300 MHz to 3 GHz
  - C: 2 - 30 MHz
- 110: (Q77) A sound wave that moves back and forth in the direction of propagation is an example of which of the following types of wave motion?
- A: Transverse.
  - o B: Longitudinal.
  - o C: Concentric.
- 111: (Q624) A thermocouple can be made of:
- o A: two metal conductors of the same nature fixed together at two points.
  - B: 'two metal conductors of different nature fixed together at two points.'
  - o C: a three wire coil.
- 112: (Q370) What regulates the cooled air coming out of the pre-cooler?
- A: The PRSOV (Pressure Regulating and shut-off Valve).
  - o B: The FAMV (Fan Air Modulating Valve).
  - o C: The HPSOV (High Pressure Shut-Off Valve).
- 113: (Q317) What happens if a component has an internal hydraulic leak?
- A: increase in fluid temperature.
  - o B: increase in fluid pressure.

o C: fluid loss.

114: (Q150) The Flight Management Computer (FMC) position is:

o A: another source of aircraft position; it is independent of other position sources (IRS, Radio, ILS etc).

o B: the actual position of the aircraft at any point in time.

• C: the computed position based on a number of sources (IRS, Radio, ILS, GPS etc).

115: (Q379) Flight director command bars indicate

• A: Direction in which aircraft is to be manoeuvred.

o B: Direction in which the beacon is.

o C: Direction in which aircraft is flying.

116: (Q285) What kind of data do we find on the labels of a portable fire extinguisher?

o A: The manufacturer and approval date and instructions to use.

• B: The manufacturer name and P/N & S/N. Approval date and instructions to use. Extinguisher type, weight details and last check or expire date. In the bottle usually the manufacturers date is engraved.

o C: The manufacturer name. P/N & S/N. The colour will say the type (green=water, red=halon). The press indicator will show if the bottle is filled to level.

117: (Q558) What is the effect of a single failure of a fly-by-wire system?

• A: It has no effect on the aircraft's operation.

o B: It will reduce the operational height and speed.

o C: It will limit the flight profile.

118: (Q590) Compressibility error of the ASI is normally corrected by:

o A: Error is insignificant and can be ignored.

• B: The use of the navigation computer by the pilot.

o C: The calibration of the instrument.

119: (Q575) If the static vent becomes blocked on an unpressurized aircraft, what could the pilot do?

o A: Select standby pitot source.

• B: Break the VSI glass.

o C: Open the window.

120: (Q526) Which priority do announcements from the flight deck have?

o A: Priority 5.

o B: Priority 2.

• C: Priority 1.

121: (Q104) VHF is used by ground control facilities and aircraft or by aircraft and other aircraft on one of ..... possible frequency channels with ..... spacing between channels.

• A: 720 - 25 kHz

o B: 360 - 8.33 kHz

o C: 2280 - 50 kHz

122: (Q226) What supplies in a turbo fan cold air system, the heat exchanger cooling air?

- o A: Air bled directly from engine or through blower.
- o B: Air bled from cabin air supply duct.
- C: Fan drawn ambient air.

123: (Q559) The advantages of fly-by-wire control are: 1. reduction of the electric and hydraulic power required to operate the control surfaces 2. lesser sensitivity to lightning strike 3. direct and indirect weight saving through simplification of systems 4. immunity to different interfering signals 5. improvement of piloting quality throughout the flight envelope The combination regrouping all the correct statements is:

- o A: 2 and 3
- B: 3 and 5
- o C: 1, 4 and 5

124: (Q407) Which airplane behavior will be corrected by a yaw damper?

- o A: Spiral dive.
- o B: Tuck under.
- C: Dutch roll.

125: (Q388) Coordinated autopilot turns are achieved by

- A: yaw rate gyro signals.
- o B: aileron to elevator crossfeed.
- o C: aileron to rudder crossfeed.

126: (Q661) The Ground Proximity Warning systems mode 3 is activated when

- A: An excessive height loss is experienced after take-off during go-around.
- o B: The aircraft is flying into rising terrain.
- o C: The barometric descent rate is excessive with respect to the aircraft height above the terrain.

127: (Q635) Increasing the angular momentum of a gyro rotor will:

- o A: decrease the gyroscopic rigidity.
- B: increase the gyroscopic rigidity.
- o C: have no substantial effect on gyroscopic rigidity.

128: (Q390) The fundamental components of an autopilot control loop are:

- A: rate gyro, servomotor, error signal generator.
- o B: rate gyro, servo motor, torque limiter.
- o C: torque limiter, error signal generator, servomotor.

129: (Q629) The quantity of fuel in the tanks is measured by capacitor type contents gauges. The working principle of these sensors is to measure the:

- o A: height of the fuel.
- o B: di-electric resistivity of the fuel.
- C: charge of condensers.

130: (Q772) A passenger with a laptop can access to e-mail and internet applications in the...

- o A: Flight Operations Domain.
- B: Communication & Cabin Domain.
- o C: Avionics Domain.

131: (Q666) Hard iron is the name given to a metal which:

- o A: Is difficult to magnetize and loses its magnetism easily.
- B: Is difficult to magnetize and retains its magnetism.
- o C: Is easy to magnetize and loses its magnetism easily.

132: (Q548) Which device is used to dump lift?

- o A: trailing edge flaps.
- B: spoiler.
- o C: leading edge flaps.

133: (Q524) Which system do you have to use if you want listen music in an aircraft?

- o A: the VOR (VHF Omni Range) to the frequency of a local commercial FM radio station and then figure out how to couple it to the aircraft PA system.
- o B: the VHF radio to the frequency of a local commercial FM radio station and then figure out how to couple it to the aircraft PA system.
- C: the ADF (Automatic Direction Finder) to the frequency of a local commercial AM radio station and then figure out how to couple it to the aircraft PA system.

134: (Q385) An automatic flight control system:

- A: is another name for an autopilot system.
- o B: applies flight data to the auto pilot system.
- o C: can only be used in EFIS equipped aircraft.

135: (Q204) What kind of light is used as cabin flood lighting?

- o A: Incandescent light bulbs.
- o B: Spot lights
- C: Fluorescent tubes.

136: (Q540) Active load control involves....

- o A: limiting the deflection of control surface with airspeed.
- B: operating control surfaces in an unconventional manner.
- o C: intervention & monitoring the human pilot.

137: (Q10) What is the main purpose of a Frise aileron?

- o A: Increase drag on the up going wing.
- B: Increase drag on the down going wing.
- o C: Help pilot overcome aerodynamic loads.

138: (Q235) What must be the minimum humidity in the cabin?

- A: 30 %.
- o B: 20 %.
- o C: 60 %.

139: (Q486) The antenna of an airborne weather radar is stabilised....

- o A: in attitude in relation to the vertical plane.
- B: in attitude in relation to the horizontal plane.
- o C: in pitch only, when 0o tilt is selected.

140: (Q683) Airspeed is shown:

- o A: on both EHSIs.
- o B: only on the pilot in commands EHSI.
- C: on both EADIs.

141: (Q72) For a frequency of 121.95 MHz, what is the wavelength?

- o A: 2.46 km
- o B: 2.46 cm
- C: 2.46 m

142: (Q771) Documentation for the IFE (In-Flight Entertainment) System is part of the...

- A: Communication & Cabin Domain
- o B: Avionics Domain
- o C: Flight Operations Domain.

143: (Q253) After landing the outflow valve is set to release the remaining pressure....

- o A: full open at touchdown.
- o B: rapidly open.
- C: at a fixed rate.

144: (Q278) During a fire bottle squib test, the green light illuminates. This indicates:

- o A: That the squib is good.
- o B: That the squib has fired.
- C: That the squib and firing circuits are OK.

145: (Q268) How is avionics smoke detected?

- o A: By carbon monoxide detectors in the avionics bay.
- B: By sampling the air extracted from the avionics compartment racks.
- o C: By smoke detectors in the avionics boxes.

146: (Q721) Helicopter rotor track and balance is done by

- A: the 'HUMS' (Health and Usage Monitoring System).
- o B: the 'Low Cycle Fatigue Counter'.
- o C: the 'Damage Tolerance Monitoring System'.

147: (Q289) How is fuel supplied to a turbine engine?

- o A: by a gravity feed pump.
- B: by a fuel boost pump.
- o C: by suction from the engine driven fuel pump.

148: (Q710) Data loading is a....

- o A: reading information facility.
- B: reading or writing information facility.
- o C: writing information facility.

149: (Q453) Before an aeroplane is able to make an automatic landing the

- o A: ground radio aids must be at CAT II.

- o B: ground radio aids must be at least CAT I.
- C: ILS system must be working.

150: (Q195) Which of the following circuit breakers CANNOT be reset while the fault exists?

- o A: Automatic reset circuit breaker.
- o B: Electromagnetic circuit breakers.
- C: Trip free circuit breaker.

151: (Q386) Autopilot disengagement is....

- o A: a caution light and an aural warning.
- B: an aural warning and flashing light.
- o C: an aural warning only.

152: (Q395) The GA mode is usually initiated by....

- A: pressing a button on thrust levers.
- o B: making a selection on the mode control panel.
- o C: pressing a button on the autopilot control panel.

153: (Q511) A hyperbola is a line joining all points where the difference....

- o A: of distance between two lines is different.
- o B: in time between two fixed points is different.
- C: of distance between two fixed points is the same.

154: (Q421) An automatic pitch trim system employs a separate pitch trim servomotor which operates....

- o A: in series with the autopilot pitch control servo.
- o B: as a stand-alone system.
- C: in parallel with the autopilot pitch control servo.

155: (Q135) What are the primary navigation inputs used by RNAV system?

- o A: Nav Aids, Mapping Radar, FMC.
- B: Nav Aids, INS, FMC.
- o C: INS, Nav Aids, TAS and Drift.

156: (Q194) What type of transformer is shown in the figure below?

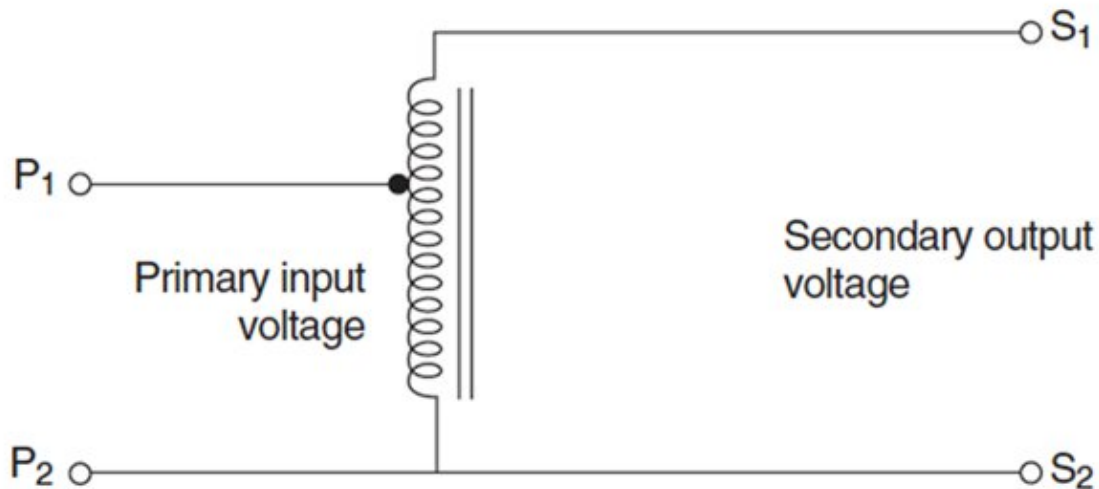

- A: Autotransformer
- o B: Transformer rectifier.
- o C: Current transformer

157: (Q549) In a turn, wing spoilers may be deployed....

- o A: to act as an airbrake, interacting with the ailerons.
- o B: in unison with both the up going and down going ailerons.
- C: to assist the up going aileron.

158: (Q674) A FDR fitted to an aircraft of over 5700kgs after April 98 must record for:

- A: 25 hours.
- o B: 60 minutes.
- o C: 30 minutes.

159: (Q327) The inflatable tube of the de-icer boots is made of ...

- o A: natural rubber.
- B: rubberised fabric.
- o C: synthetic rubber.

160: (Q113) Operation of an ELT.... 1. is automatic on impact by a 'G' force switch in the transmitter.

2. can be done through a remote switch in the cockpit. 3. can be done by a switch on the unit itself.

4. can be turned off with the switch on the case.

- A: 1, 2, 3 and 4.
- o B: 2, 3 and 4.
- o C: 1, 2 and 4.

161: (Q243) The standard cabin pressure during flight on civil airliners is....

- o A: maintained on ground level conditions.
- o B: is equal to the air pressure on 15000 feet.
- C: is equal to the air pressure on 8000 feet.

162: (Q263) In a dual loop fire detection system. 'Loop A' fire warning is shown, this means:

- o A: Loop A has detected a fire and loop B is faulty.
- o B: Loop a is faulty.
- C: A fire test must be performed to determine the condition of the loops.

163: (Q58) Pressure Error (PE) will cause an altimeter to:

- o A: consistently under-read in a climb or descent.
- o B: only over-read in a climb.
- C: either over-read or under-read in level flight.

164: (Q198) On a large commercial aircraft, which bus will be powered as soon as external power is connected?

- o A: The external power bus.
- o B: Battery bus.
- C: The ground handling bus.

165: (Q73) What is the major advantage of the telegraph over earlier methods of communication?

- o A: Security.
- o B: Larger messages.
- C: Range and speed.

166: (Q448) When an automatic landing is interrupted by a go-around: 1. The auto throttle reacts immediately upon the pilot action on TO/GA switch in order to recover the maximum thrust. 2. The autopilot monitors the climb and rotation of the airplane. 3. The autopilot retracts the landing gear and reduces the flap deflection in order to reduce the drag. 4. The pilot performs the climb and the rotation of the airplane. 5. The pilot retracts the landing gear and reduces the flap deflection in order to reduce the drag. The combination regrouping all the correct statements is:

- o A: 1, 2, 3.
- o B: 1, 3, 4.
- C: 1, 2, 5.

167: (Q519) The Doppler Navigation System is based on....

- o A: radio waves refraction in the ionosphere.
- o B: pulse shift transmission.
- C: radar principles using frequency shift.

168: (Q648) A faulty rate of turn and bank indicator in a general aviation aircraft may be checked by a pilot in the air by....

- o A: slipping the aircraft right or left.
- B: timing an indicated rate one turn.
- o C: comparing the indication with the attitude indicator.

169: (Q430) The flight director is displayed on the....

- o A: EHSI
- B: EADI
- o C: bearing indicator

170: (Q185) What type of voltage regulator is shown in the figure below?

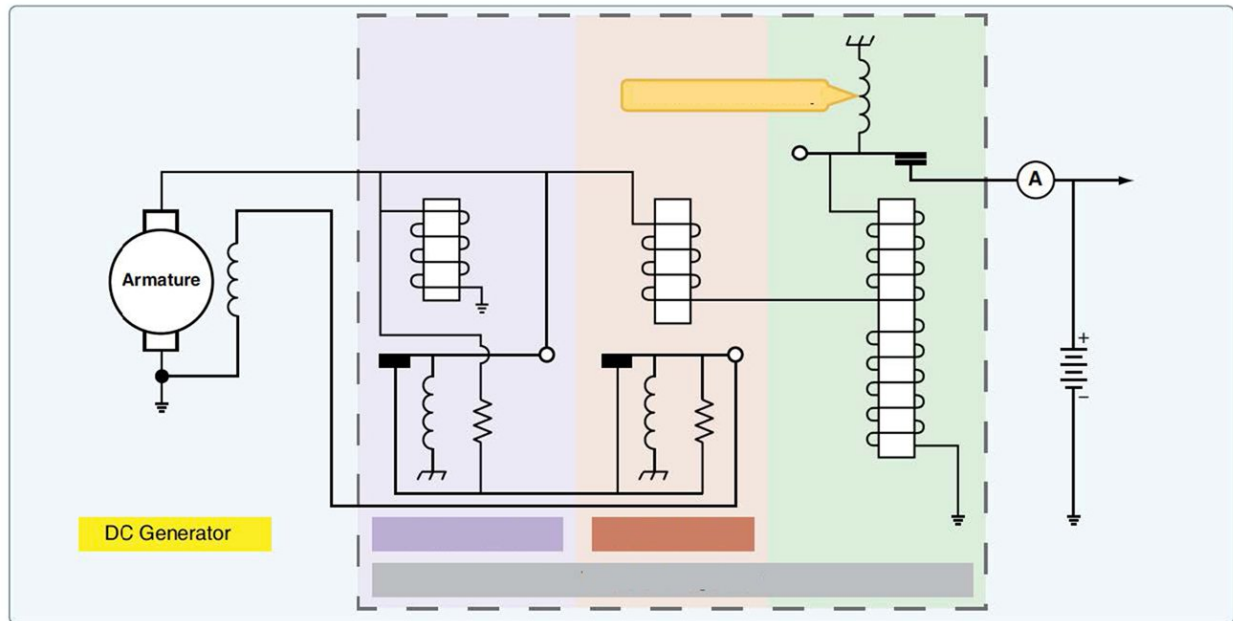

- A: Three-unit voltage regulator.
- o B: Reverse current delay.
- o C: Carbon pile voltage regulator.

171: (Q482) What does the Radar contour button do?

- o A: Alter the video amplifier.
- B: Alter the display presentation.
- o C: Alter the transmitter power.

172: (Q425) When the altitude select mode is engaged on a jet transport airplane equipped with autopilot (AP) and auto-throttle (ATS) systems the....

- o A: calibrated airspeed (CAS) is maintained constant by the autopilot by means of elevator.
- B: indicated airspeed (IAS) is maintained constant by the autopilot by means of elevator.
- o C: true airspeed (TAS) is maintained constant by the auto-throttle system.

173: (Q2) The axes of an aircraft by definition must all pass through the:

- o A: centre of pressure (CP).
- o B: aircraft datum.
- C: centre of gravity (CG).

174: (Q286) What is the main reason to install only halon-type portable fire extinguisher in the cockpit?

- o A: Halon avoids smoke, keeping the cockpit 'visual'.
- o B: Because halon fire-bottles can be made much smaller and lighter and so much easier to handle by the pilot from the seat.
- C: Because on fires in electronics you may only use halon.

175: (Q636) The gyro mass is concentrated at its edge to....

- A: increase its rigidity.
- o B: increase its speed of rotation.
- o C: relieve bearing wear.

176: (Q207) Which statement is true?

- o A: When operating the external emergency light switch both internal and external lights come on.
- B: When the internal emergency light switch is used both internal and external emergency light come on.
- o C: Operating the internal emergency light switch only turns on the internal emergency lights.

177: (Q418) In the automatic trim control system of an autopilot, automatic trimming is normally effected about the :

- A: pitch axis only.
- o B: pitch and roll axes only.
- o C: pitch, roll and yaw axes.

178: (Q103) The VHF (very high frequency) is the standard civil short range communication facility using the band of frequencies between

- o A: 2 and 29.999 MHz.
- B: 118 and 136 MHz.
- o C: 1.5 to 1.6 GHz.

179: (Q55) How are skin panels strengthened?

- o A: struts.
- B: stringers.
- o C: cleats.

180: (Q733) The ARINC 664 Ethernet has a transport rate of ...

- o A: 100 kilobits per second.
- o B: 100 gigabits per second.
- C: 100 megabits per second.

181: (Q744) The passengers can listen to the selected audio and video channels by connecting a headset to ...

- o A: the IFES SDU (In-Flight Entertainment System Smart Display Unit).
- o B: the IFES SEB (Seat Electronic Box).
- C: the IFES RJU (Remote Jack Unit).

182: (Q494) What does the term AIR-GROUND COMMUNICATION mean?

- o A: One-way communication from stations or locations on the surface of the earth.
- B: Two-way communication between aircraft and stations or locations on the surface of the earth.
- o C: Any communication from aircraft to ground station requiring handling by the Aeronautical Fixed Telecommunication Network (AFTN).

183: (Q534) Anti-servo tabs....

- o A: are directly connected to the control column.
- B: move in the same direction as the control surface.
- o C: move in the opposite direction to the control surface.

184: (Q15) What do ruddervators do?

- o A: control yaw and roll.

- B: control pitch and yaw.
- o C: control pitch and roll.

185: (Q449) During an automatic landing, the aircraft descent rate is sensed by

- A: radio altimeters.
- o B: pitch rate gyros.
- o C: vertical accelerometers.

186: (Q577) In high speed flight at high altitude, the static source will suffer:

- A: position error.
- o B: temperature error.
- o C: barometric error.

187: (Q339) On all aircraft equipped with retractable landing gear, some means must be provided to ..

- o A: retract and extend the landing gear if the normal operating mechanism fails.
- o B: prevent extension of the landing gear at airspeeds greater than that determined structurally safe.
- C: extend the landing gear if the normal operating mechanism fails.

188: (Q775) Which of the following instruments are flight instruments? 1. Air speed indicator. 2. Altimeter. 3. Gyro horizon. 4. Global navigation satellite system. 5. Inertial reference system.

- o A: 3, 4 and 5.
- B: 1, 2 and 3.
- o C: 1, 3 and 5.

189: (Q576) A partially blocked air filter will cause the air-driven turn indicator to:

- o A: indicate zero rate of turn.
- o B: over read the correct rate of turn.
- C: under read the correct rate of turn.

190: (Q276) Which Halon type doesn't use a pressurisation agent?

- A: Halon 1301.
- o B: Halon 1001.
- o C: Halon 1211.

191: (Q612) Position error:

- A: may be reduced by the fitting of static ports.
- o B: will depend solely on the attitude of the aircraft.
- o C: will usually decrease with an increase in altitude.

192: (Q201) Which lights can be used to detect ice build-up?

- o A: Position lights.
- o B: Runway turn-off lights.
- C: Wing scan lights.

193: (Q92) At frequencies above 100 MHz, the greatest attenuation of rf energy from raindrops is caused by which of the following factors?

- o A: absorption.
- B: scattering.

o C: ducting.

194: (Q643) With reference to a turn and bank indicator, the aircraft is in a balanced turn if:

- A: the turn is indicated and the slip is zero.
- o B: the turn pointer and slip indicator are zero.
- o C: the turn pointer and slip indicator are displaced on the same side.

195: (Q689) The level of alert for conditions that require immediate flight crew awareness and subsequent flight crew response is..... Engine overheat or low oil pressure are typical examples.

- o A: alert message.
- B: a warning.
- o C: a caution.

196: (Q318) Throttling valves in a hydraulic system are used to ...

- o A: limit the maximum pressure.
- o B: restrict the rate of pressure build up.
- C: control the flow rate of system operation.

197: (Q646) When turning right onto the runway prior to take-off, the ball on the turn and bank indicator will:

- A: move to the left.
- o B: move to the right.
- o C: stay central in the turn.

198: (Q220) A refrigerant is used in....

- A: a vapour cycle.
- o B: an air cycle machine.
- o C: a pneumatic pump.

199: (Q616) A direct reading aircraft thermometer usually consists of a bimetallic helix protruding into the airstream. Movement of the pointer over the temperature scale will depend upon:

- o A: increase in pressure as airspeed increases.
- B: different coefficients of expansion of the two metals.
- o C: difference in electrical resistance of the two metals.

200: (Q127) What is the colour sequence when passing over an Outer, Middle and Inner Marker beacon?

- o A: amber(yellow) - white - green
- o B: blue - green - white
- C: blue - amber(yellow) - white

201: (Q424) When the bank angle limit is applied to the autopilot , it means

- A: the max roll angle that can be demanded by the autopilot.
- o B: the max aileron angle that can be commanded.
- o C: maximum rudder deflection.

202: (Q44) The primary purpose of the tail rotor is

- o A: to give lateral stability.

- B: to counteract torque.
- o C: to give directional control.

203: (Q349) A nose wheel steering control system....

- o A: allows the nosewheel to caster freely at all times.
- o B: prevents the nosewheel from castering at all times.
- C: allows the nosewheel to caster within preset limits when in the neutral position.

204: (Q68) What causes the glow which can be seen during the initial stage of a lightning strike?

- A: Ionization of the air.
- o B: Burning of metal.
- o C: Static discharging.

205: (Q631) A float fuel gauge system is....

- o A: cannot be adjusted.
- B: adjusted when tanks are empty.
- o C: adjusted when tanks are full.

206: (Q136) Which one of the following inputs to an Area Navigation System (R-NAV) comes from an external, not on-board, system?

- o A: Magnetic heading.
- o B: Inertial Navigation System (INS) position.
- C: VOR/DME radial/distance.

207: (Q188) What type of bus is show in the figure below?

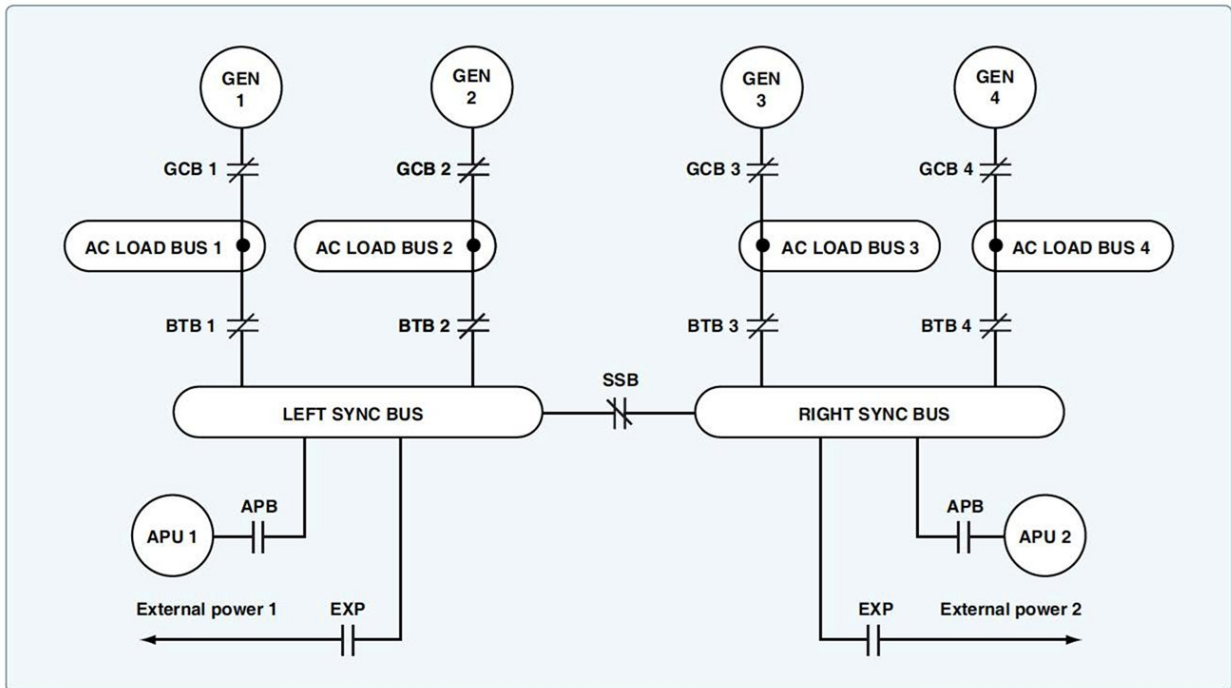

- A: Split Parallel Bus
- o B: Parallel bus
- o C: Emergency bus

208: (Q715) An Electronic Library System consists of : 1. a LCD. 2. an optical disk drive. 3. a printer. 4. a workstation platform. 5. capacitive touch screen overlay. 6. A keyboard.

- A: 1, 2, 3, 4 and 5.
- o B: 1, 3, 4 and 5.
- o C: 1, 2, 3 and 6.

209: (Q144) Which of the following is the FMS normal operating condition in the cruise?

- A: LNAV and VNAV.
- o B: LNAV or VNAV.
- o C: LNAV only

210: (Q754) Which unit gathers information for proximity sensors to determine the flight phase and sends discretes to the System Controller to provide it with flight phase information for the passengers?

- A: The PSEU (Proximity Switch Electronics Unit).
- o B: The FMS (Flight Management System).
- o C: The INS (Inertial Navigation System) or IRS (Inertial Reference system).

211: (Q313) What is the normal operating pressure of a hydraulic system?

- o A: 1800 PSI.
- B: 3000 PSI.
- o C: 300 PSI.

212: (Q681) The symbols A, C and E are best described respectively as: (See the figure)



**A**

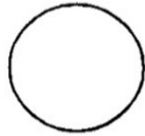

**B**



**C**



**D**



**E**

- A: (A) active waypoint aircraft currently navigating to - (C) navigation aid - (E) off route waypoint.
- o B: (A) next waypoint - (C) navigation aid - (E) airport.
- o C: (A) off route waypoint - (C) navigation aid - (E) a navigation point making up selected route.

213: (Q717) Information to be printed is sent to the printer ...

- o A: from the CDU (Control Display Unit).
- B: from the CMC (Central Maintenance Computer).
- o C: from the FMC (Flight Management Computer).

214: (Q75) Radio waves travel at what speed?

- o A: Speed of the Earth's rotation.
- B: Speed of light.
- o C: Speed of sound.

215: (Q378) The definition of fail operational is the ability of a system to

- o A: disconnect but leave the aircraft out of trim.
- o B: disconnect and leave the aircraft in trim.
- C: continue to control after any first fault.

216: (Q703) The Primary Flight Display (PFD) displays information dedicated to:

- A: piloting.
- o B: systems.
- o C: engines and alarms.

217: (Q777) The pilot receives an audible warning on the flight deck as the aircraft is descending to land.

The most likely reason for this warning is ...

- o A: the brake temperature is too high.
- B: the landing gear is not locked down.
- o C: the wheel speed is too high.

218: (Q686) An EFIS, having a control panel, symbol generators and a remote light sensor, also has:

- A: EADIs and EHSIs.
- o B: EADIs and WXR displays.
- o C: EADIs and EICAS.

219: (Q225) When the refrigerant loses heat in a vapour cycle system....

- A: the vapour converts to a liquid.
- o B: the liquid converts to a vapour.
- o C: the liquid evaporates to the environment.

220: (Q675) Where in the aircraft should the FDR be fitted according to the EASA regulations?

- o A: In the wings.
- B: At the rear of the aircraft.
- o C: In the nose landing gear bay.

221: (Q371) What happens if the pneumatic system bleed air is OFF, purposely or by failure?

- A: the OFF light in the control switch illuminates and a warning appears on the ECAM or EICAS screen.
- o B: the OFF light in the control switch illuminates and a memo appears on the ECAM or EICAS screen.
- o C: a caution appears on the ECAM or EICAS screen.

222: (Q692) The alerting system functional components used to accomplish the alerting and informing functions for warnings should include:

- o A: master visual alert or visual information and master aural alert.
- o B: visual information, master aural alert and voice information.
- C: master visual alert, and visual information and master aural alert.

223: (Q719) The printer used in the cockpit is....

- o A: an inkjet printer.
- o B: a laser printer.
- C: a dot matrix printer.

224: (Q126) In which frequency band do VOR transmitters operate?

- A: VHF.
- o B: SHF.
- o C: UHF.

225: (Q167) What determines the amount of induced voltage?

- o A: The length of the field frame.
- o B: The diameter of the conductor.
- C: The speed at which the conductor moves through the magnetic field.

226: (Q592) During descent, a blockage of the static source will cause the ASI to:

- A: over-read.
- o B: under-read.
- o C: either, depending on the attitude or configuration.

227: (Q162) Which type of battery can experience cell reversal and how can it be prevented?

- o A: NiCad battery. Prevented by always fully discharging the battery.
- o B: Lead-acid battery. Prevented by fast charging battery.
- C: NiCad battery. Prevented by never fully discharging the battery.

228: (Q306) One reason for fitting an accumulator in a hydraulic system is to....

- o A: relieve excess pressure.
- o B: minimize the possibility of pump cavitation.
- C: absorb pressure surges.

229: (Q498) An ARINC 429 binary coded decimal data word occupies bits

- o A: 1 to 8
- o B: 11 to 29
- C: 11 to 28

230: (Q762) What is the main protocol of communication in the open world?

- o A: ARINC 429.
- o B: ARINC 629.
- C: Ethernet.

231: (Q175) The output sine waves of a 3-phase alternator will be separated by:

- A: 120 degrees
- o B: 60 degrees
- o C: 90 degrees

232: (Q130) Concerning conventional and Doppler VORs (DVOR), which of the following is correct?

- o A: The DVOR will always have a 'D' in the ident.
- B: It is not possible for the instrumentation display to determine which type is being used.
- o C: The DVOR has a higher audio ident tone than the standard VOR.

233: (Q634) A force applied to the spinning axis of a gyro is precessed:

- o A: through 90° in the direction of the force.

- o B: through an angle equivalent to  $15.04^\circ \times \sin \lambda$  (latitude).
- C: through  $90^\circ$  in the direction of rotor spin.

234: (Q768) On which system are scheduled maintenance tasks shown when a time or cycle limit occurs in an airplane system?

- o A: only on the maintenance laptop.
- o B: on the maintenance laptop and the electronic flight bags.
- C: on the multifunction displays, the electronic flight bags and the maintenance laptop.

235: (Q121) ILS is subject to false glide paths resulting from:

- o A: ground returns ahead of the antennas.
- o B: false signals reflected by nearby obstacles.
- C: multiple lobes of radiation patterns in the vertical plane.

236: (Q333) When operating a windscreen wiper on the ground, make sure to....

- o A: place soft cloth between blade and window.
- o B: use slow wiper only.
- C: use water as lubricant when operating.

237: (Q670) The purpose of fitting an expansion unit to a direct reading compass is to....

- A: compensate for expansion/contraction of the liquid.
- o B: compensate for leaks in the system.
- o C: minimize liquid swirl.

238: (Q210) Which of the following statements is incorrect? A turbo compressor....

- o A: is used as a supplemental use source of bleed air.
- o B: can be switched on and off by the crew.
- C: is used on turbo-prop and piston engine.

239: (Q41) How do the rotors turn on a co-axial rotor system?

- o A: They counter-rotate on separate masts.
- B: They counter-rotate on a common shaft.
- o C: Both rotate in the same direction on a common shaft.

240: (Q124) The amplitude modulation and the colour of an outer marker (OM) is:

- o A: 400 Hz, amber.
- B: 400 Hz, blue.
- o C: 3000 Hz, amber.

241: (Q704) The Head Up Display (HUD) is a device allowing the pilot, while still looking outside, to have:

- A: a synthetic view of the instrument procedure.
- o B: a navigating control aid.
- o C: a monitoring only during Cat III precision approaches.

242: (Q287) On Large transport aircraft fuel is delivered to each engine using ...

- A: a separate system for each engine.
- o B: a parallel system.
- o C: the same system for each engine.

243: (Q16) What control surface movements will make an aircraft fitted with ruddervators yaw to the left?

- o A: Right ruddervator lowered, left ruddervator raised.
- B: Left ruddervator lowered, right ruddervator raised.
- o C: Both ruddervators raised

244: (Q282) How are fire bottles without a gauge checked?

- A: By removing from the aircraft and placing on a weighing scale.
- o B: By doing a tap test on the fire bottle.
- o C: No check has to be done as long as the bottle is not used.

245: (Q478) The TCAS 2 (Traffic Collision Avoidance System) provides: 1. traffic information (TA: Traffic Advisory) 2. horizontal resolution (RA: Resolution Advisory) 3. vertical resolution (RA: Resolution Advisory) 4. ground proximity warning The combination regrouping all the correct statements is:

- o A: 1, 2, 3 and 4.
- B: 1 and 3
- o C: 1 and 2

246: (Q751) Data from the In-Flight Entertainment system can be transferred to a terminal station on the ground

- o A: through an ethernet link when the aircraft is on the ground.
- o B: through an ethernet link when the aircraft is at the terminal.
- C: through a wireless GSM Cell Data Modem when the aircraft is at the terminal.

247: (Q525) The PA amplifier sets the priority for the audio inputs. Which has the highest priority?

- o A: Announcement from an attendant.
- B: Announcement from the flight compartment.
- o C: Boarding Music.

248: (Q160) What is the nominal voltage of a NiCad battery cell?

- o A: 2 volts.
- o B: 24 volts.
- C: 1.2 volts.

249: (Q85) Ionization in the atmosphere is produced chiefly by which of the following types of radiation?

- o A: cosmic radiation.
- o B: Alpha radiation.
- C: ultraviolet radiation.

250: (Q644) The rate gyro indicates the correct rate of turn when the ..(1).... precession due to the spring is ..(2)..... to the ..(3)..... force.

- A: (1) secondary - (2) equal - (3) primary applied.
- o B: (1) torqued - (2) opposite - (3) primary precessed.
- o C: (1) secondary - (2) opposite - (3) primary precessed.

251: (Q164) What product does the sump jar contain in the vent line of a lead-acid battery installation?

- A: Bicarbonate of soda and water.
- o B: Distilled water.
- o C: Boric acid.

252: (Q368) What type of air pump is commonly used in low pressure pneumatic systems?

- o A: Piston pump.
- o B: Centrifugal pump.
- C: Vane pump.

253: (Q495) The ADS-B (Automatic Dependent Surveillance Broadcast) digitises the position information derived from....and broadcasts it as part of a data stream.

- o A: INS or IRS.
- o B: R-NAV system.
- C: GNSS.

254: (Q70) With reference to antennas, parasitic elements are:

- o A: unfed elements which make the antenna radiation pattern omnidirectional.
- o B: dipole or folded dipole radiating elements.
- C: unfed elements which make the radiation pattern directional.

255: (Q778) What are the reasons for automatic deployment of emergency oxygen? 1. Cabin depressurization. 2. Smoke in the cabin. 3. Insufficient cabin air in-flow.

- A: 1 + 3
- o B: 1 + 2
- o C: 1 + 2 + 3

256: (Q593) Which of the following is not an error associated with the ASI?

- o A: Position error.
- B: Barometric pressure error.
- o C: Compressibility error.

257: (Q451) In a duplex system, the detection of a failure of one simplex system will disconnect....

- o A: the failed system and carry on with an autoland.
- o B: all channels.
- C: the failed system and continue in a trimmed safe attitude.

258: (Q180) When will the hydraulic motor generator (HMG) supply power?

- A: Automatically when both main AC buses lose power.
- o B: Automatically when the main battery is discharged.
- o C: Manually, when the pilot switches it on after both main AC buses lose power.

259: (Q463) A landing will be considered to be performed in the AUTOMATIC mode when: 1. the autopilot maintains the airplane on the ILS beam until the decision height is reached then is disengaged automatically. 2. the auto throttle maintains a constant speed until the decision height is reached then is disengaged automatically. 3. the autopilot maintains the airplane on the ILS beam until the flare. 4. the auto throttle decreases the thrust when the height is approximately 30 ft. 5. the flare and the ground roll are performed automatically. The combination regrouping all the correct statements is:

- A: 3, 4 and 5.
- o B: 1 and 4.
- o C: 2, 3 and 5.

260: (Q241) Which of the following modes of pressurization places the highest load demands on the aircraft structure?

- A: Isobaric mode.
- o B: Unpressurized.
- o C: Constant-differential pressure.

261: (Q422) Automatic steering of the aircraft after touch down is affected by

- A: the runway localiser.
- o B: the airfield marker beacon.
- o C: the area navigation system.

262: (Q563) The rate-of-turn is the:

- o A: yaw rate in a turn.
- B: change-of-heading rate of the aircraft.
- o C: aircraft speed in a turn.

263: (Q382) A single axis autopilot system provides....

- A: control about the roll axis.
- o B: stabilisation about the normal axis.
- o C: control about the pitch axis.

264: (Q436) The autothrottle maintains a specific value of thrust in terms of:

- o A: N1, Mach and airspeed.
- o B: N2, Mach and airspeed.
- C: EPR, N1, Mach and airspeed.

265: (Q321) Under which condition does an air pressure operated ice detector work?

- o A: A build up of ice causes a torque switch to illuminate a flight deck annunciator.
- o B: It has to be completely covered in ice before causing an alarm to sound on the flight deck.
- C: A build up of ice on the leading edge causes a warning light to illuminate on the flight deck.

266: (Q132) In an ADF system, night effect is most pronounced:

- o A: when the aircraft is at high altitude.
- o B: during long winter nights.
- C: at dusk and dawn.

267: (Q332) On large transport aircraft, the windshield wiper system is....

- A: independent on each side with different power sources.
- o B: independent on each side but with the same power source.
- o C: one system for both sides but with the same power source.

268: (Q687) Alarms are standardized and follow a code of colors. Those requiring action but not immediately, are signaled by the color:

- A: amber.

- o B: red.
- o C: flashing red.

269: (Q520) Exit signs must have ...

- o A: white electrically or self illuminated letters on a black background.
- B: red letters on a white electrically or self illuminated background.
- o C: black letters on a white electrically or self illuminated background.

270: (Q645) A leaking case on an air-driven turn and bank indicator will cause:

- o A: no appreciable error.
- B: the turn to under-read.
- o C: the turn to over-read.

271: (Q476) On a TCAS 2 (Traffic Collision Avoidance System) the preventive 'resolution advisory' (RA) is a 'resolution advisory':

- A: that advises the pilot to avoid certain deviations from the current vertical rate but does not require any change to be made to that rate.
- o B: asking the pilot to modify the heading of his aircraft.
- o C: asking the pilot to modify effectively the vertical speed of his aircraft.

272: (Q573) During a walk around inspection, you observe covers over the pitot probes. Which items will be affected if the covers are not removed?

- o A: Airspeed, altimeter and autopilot.
- B: Flight recorder, airspeed and autopilot.
- o C: Flight recorder, autopilot, vertical speed indicator and airspeed.

273: (Q52) In a monocoque structure, which component carries the majority of the loads?

- o A: Stringers.
- o B: Longerons.
- C: Skin.

274: (Q755) Which unit lets the crew monitor and control the CSS (Cabin Services System)?

- A: The CAP (Cabin Attendant Panel).
- o B: The PCU (Passenger Control Unit).
- o C: The SDU (Smart Display Unit).

275: (109) The HF .....matches the antenna impedance to the transceiver output over the HF frequency range.

- o A: transceiver
- o B: FDAU (Flight data acquisition unit)
- C: antenna coupler

276: (Q49) What is the result of moving the helicopter forward?

- o A: pitch angle of all blades decreasing.
- o B: retreating blade flapping up.
- C: advancing blade flapping up.

277: (Q639) The acceleration errors of an electrically-driven attitude indicator are reduced compared to those of a vacuum driven one by:

- o A: spinning the electrical rotor slower.
- B: inclination of the gyro spin axis.
- o C: reducing the erection rate of the gyro assembly.

278: (Q447) On an autopilot coupled approach, GO AROUND mode is engaged:

- o A: By the pilot selecting G.A. mode on the thrust computer control panel.
- B: By the pilot pushing a button located on the throttles.
- o C: If the aircraft reaches the decision height selected on the radio altimeter at a higher speed than the one selected.

279: (Q688) In a modern airplane equipped with an ECAM (Electronic centralized aircraft monitor), when a failure occurs in a circuit, the centralized flight management system: 1. releases an aural warning. 2. lights up the appropriate push-buttons on the overhead panel. 3. displays the relevant circuit on the system display. 4. processes the failure automatically. The combination regrouping all the correct statements is:

- o A: 3 and 4.
- o B: 1, 3 and 4.
- C: 1, 2 and 3.

280: (Q9) In normal flight, if the control wheel is moved to the left, what will the aileron on the right do?

- o A: remain in the same position.
- o B: move up.
- C: move down.

281: (Q45) Which control input must be used to lift the helicopter vertically into the hover?

- o A: collective pitch lever has to be lowered.
- o B: cyclic pitch lever has to be raised.
- C: collective pitch lever has to be raised.

282: (Q679) The centre of the weather return is : (See the figure)



- o A: 30 nm left of track, 15 nm ahead.
- B: 332° relative, 13 nm.
- o C: 106° relative, 18 nm.

283: (Q165) What is the dis-advantage of series wound generators?

- o A: When the aircraft electrical load increases, the output voltage remains the same.
- o B: When the aircraft electrical load increases, the output current increases.
- C: When the aircraft electrical load increases, the output voltage increases.

284: (Q499) An ARINC 429 bus uses

- o A: a single tin wire cable for each transmitter.
- o B: two bi-directional twin sheathed and earthed wires.
- C: a twisted shielded pair of wires.

285: (Q186) In a parallel bus configuration the generators will:

- A: Share the load equally among them.
- o B: Each supply their own AC bus.
- o C: Divide the load, with the strongest generators taking the biggest load.

286: (Q543) Make the best choice: The employment of active control technology presents numerous advantages, namely: 1. more stable aircraft. 2. more comfortable flight. 3. better fuel consumption. 4. possible to fly the aircraft beyond its design limitations.

- o A: 1, 2 and 4.
- B: 1, 2 and 3.
- o C: 2, 3 and 4.

287: (Q346) In an anti-skid system ...

- o A: brakes release on falling torque.
- B: brakes are modulated to give most efficient braking.
- o C: brakes release on rising torque.

288: (Q529) How is communication from the In Flight Entertainment System to a ground station achieved?

- o A: Selective Calling System (SELCAL).
- B: Aircraft Communications Addressing and Reporting System (ACARS).
- o C: Automatic Terminal Information System (ATIS).

289: (Q589) The VSI-case is fed with ..(1)..... pressure and the capsule with ..(2)..... pressure.

- A: (1) static - (2) static
- o B: (1) pitot - (2) static
- o C: (1) static - (2) pitot

290: (Q571) True airspeed is....

- A: dependent on the air density.
- o B: equal to dynamic pressure minus static pressure.
- o C: the pressure caused by the forward movement of the aircraft.

291: (Q60) Water Lines (WLs) are measured points on a

- o A: wing line.
- B: vertical line.
- o C: horizontal line.

292: (Q137) What is the required accuracy of a precision area navigation system?

- o A: 10 nautical miles.
- B: 1 nautical mile.
- o C: 5 nautical miles.

293: (Q633) The degree of rigidity of a gyro depends on:

- o A: The rotor weight only.
- o B: The rotor speed only.
- C: The rotor speed and weight distribution.

294: (Q718) Defects of the printer are notified ...

- o A: by a fault report to the CDU (Control Display Unit).
- o B: by a fault report to the CMC (Central Maintenance Computer).
- C: by way of lamps on the front of the panel itself.

295: (Q514) How do you call the waves depicted in the figure with an A?

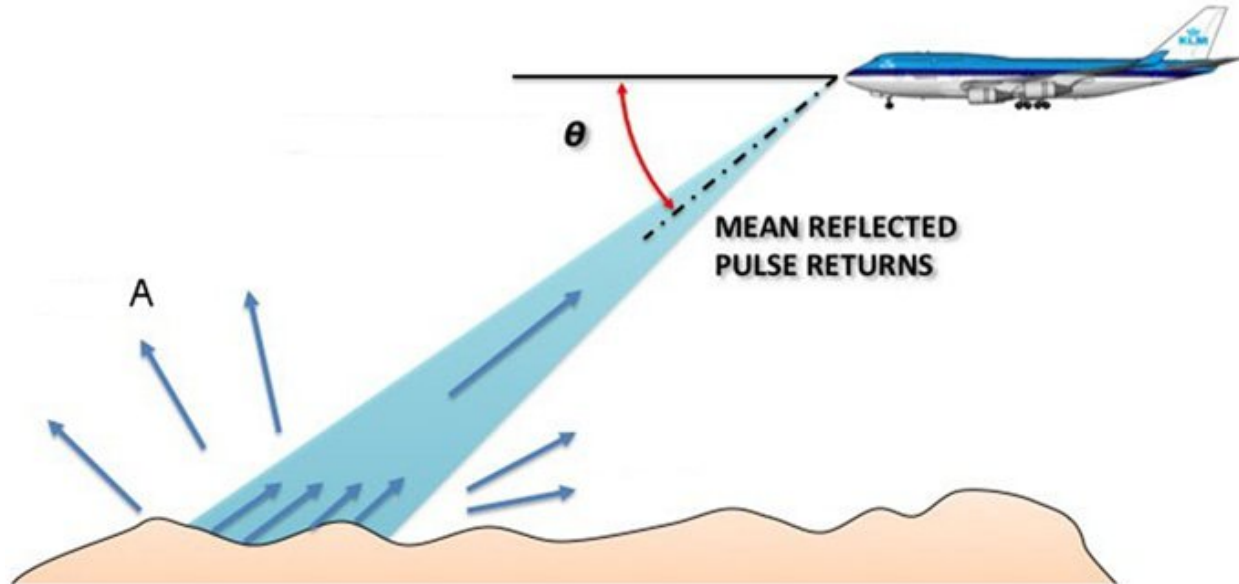

- o A: Deflected waves.
- B: Scattered waves.
- o C: Depression waves.

296: (Q752) The external communication (IFE) system provides communication with the aircraft while grounded through ...

- o A: an ethernet connection in the aircraft.
- o B: a cell modem component and an antenna located in the aircraft.
- C: a cell modem component and a terminal receiving station..

297: (Q614) Direct reading aircraft thermometer usually consists of a bimetallic element protruding into the airstream. Movement of the pointer over the temperature scale will depend on:

- o A: increase in pressure as airspeed increases.
- B: different coefficients of expansion of the two metals.
- o C: difference in electrical resistance of the two metals.

298: (Q740) This is a.... (See the figure)



- o A: LC connector (fibre optic).
- o B: Coaxial connector.
- C: QuadraX connector.

299: (Q391) What controls in a closed loop system the flight control movement?

- o A: A rate gyro.
- o B: An amplifier.
- C: A servomechanism.

300: (Q528) How are the IFES (In-Flight Entertainment System) Ethernet network set of units connected?

- A: Twisted pair wires.
- o B: Glass fiber connection.
- o C: Infrared wires.

301: (Q219) The aircraft air conditioning system keeps the....

- o A: humidity high in the cabin.
- B: cabin pressure at 8000 ft cabin altitude.
- o C: cabin altitude (pressure) at 10.000 ft.

302: (Q32) The tail rotor

- A: produces a force opposing torque reaction.
- o B: is not subject to dissymmetry of lift.
- o C: produces a force in the same direction as torque reaction.

303: (Q444) During the flair mode the A/T throttle will

- o A: disconnect autothrottle.
- o B: select reverse thrust.
- C: retard throttle to idle.

304: (Q217) What is the purpose of the air conditioning system?

- A: Control the temperature, air flow and humidity.
- o B: Increase and decrease the temperature of air and pressurize the aircraft.
- o C: Increase the temperature of air and humidity.

305: (Q426) Mode 'Localizer ARM' active on Flight Director means:

- o A: Localizer is armed and coupling will occur when flag warning disappears.
- B: System is armed for localizer approach and coupling will occur upon capturing center line.
- o C: Coupling has occurred and system provides control data to capture the centerline.

306: (Q7) How can adverse yaw when rolling about the longitudinal axis be prevented?

- o A: a smaller fin.
- B: differential ailerons.
- o C: equal deflection lateral control surfaces.

307: (Q131) A conventional VOR....

- o A: has an AM reference signal and a 150 Hz variable signal.
- o B: has an AM reference signal and a FM variable signal.
- C: has an FM reference signal and an AM variable signal.

308: (Q758) Which item provides the aircraft crew access to configuration of the IFES, the capability of storing data, and access to passenger database?

- A: the IFES Crew Panel.
- o B: the IFES File Server.
- o C: the IFES Advanced Master Control Unit (AMCU).

309: (Q401) On aircraft an auto land during auto flare the auto throttle will

- A: retard the throttle.
- o B: reverse thrust.
- o C: control throttle for a IAS.

310: (Q381) The position of a Flight Director command bars:

- A: indicates the manoeuvres to execute, to achieve or maintain a flight situation.
- o B: enables the measurement of deviation from a given position.
- o C: only displays information relating to radio-electric deviation.

311: (Q125) The BFO (Beat Frequency Oscillator) selector on an ADF receiver is used to....

- o A: find the loop 'null' position.
- B: hear the IDENT of some NDB stations radiating a continuous wave signal.
- o C: display the ident on display.

312: (Q14) How does a delta wing aircraft move about the pitch and roll axis?

- o A: ailerons.
- o B: elevators.
- C: elevons.

313: (Q393) Which modes are incompatible?

- o A: VOR + ALTITUDE HOLD
- o B: HDG + V/S HOLD
- C: G/S + ALTITUDE HOLD

314: (Q757) The seating and zones are controlled from the cabin configuration software inside the...  
(See figure)

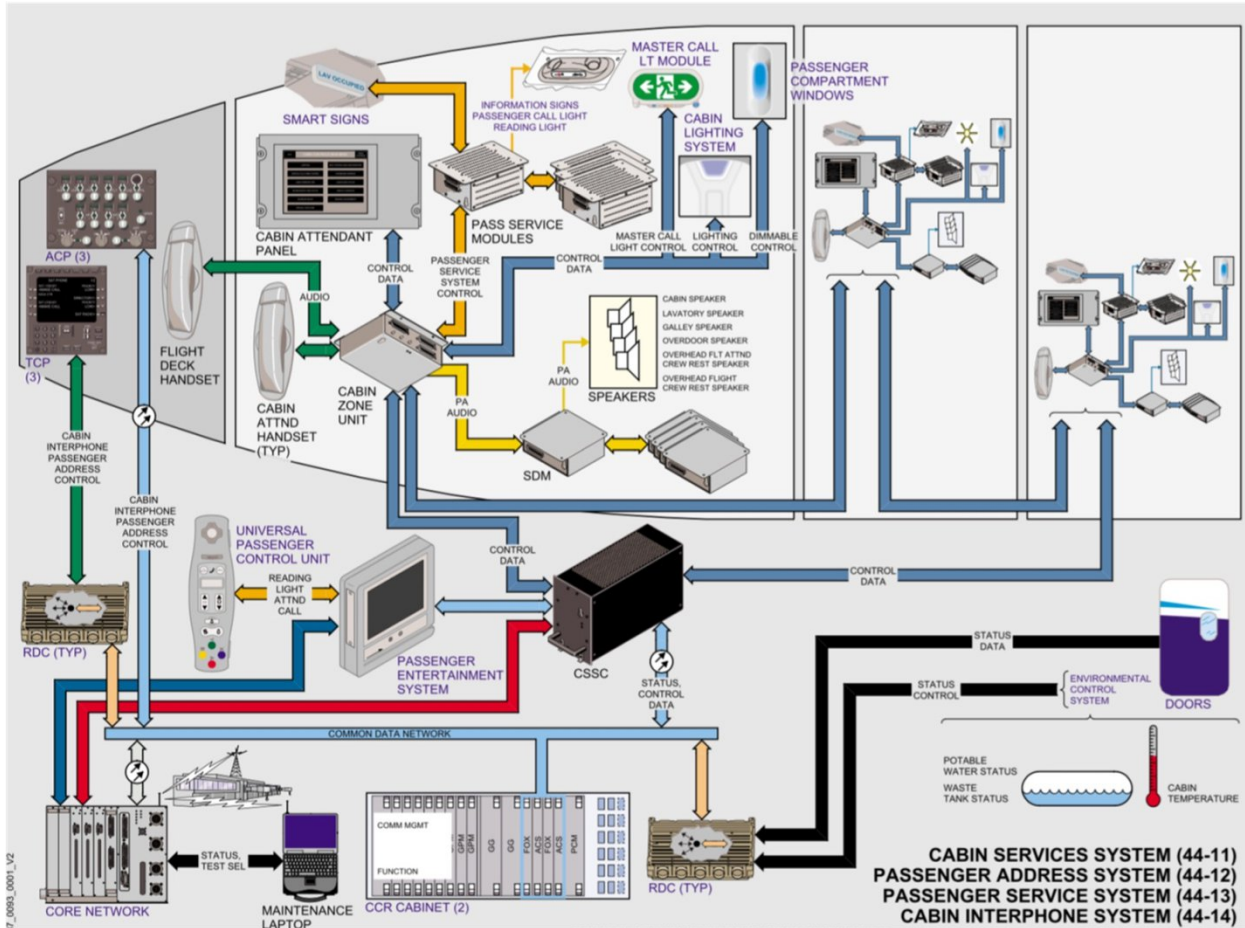

- o A: Cabin Attendant Panel.
- B: Cabin Services System Controller.
- o C: Passenger Control Unit.

315: (Q584) An aircraft takes off from an airfield 126 ft AMSL with a QFE of 994 hPa set. During flight, a regional QNH of 999 hPa is set. If the aircraft were to return to the departure point, where there had been no pressure change, without re-setting the altimeter, the height reading on landing would be:

- o A: 276 ft
- B: 150 ft
- o C: 126 ft

316: (Q483) A frequency used by airborne weather radar is:

- A: 9.375 GHz.
- o B: 8800 MHz.
- o C: 1213 MHz.

317: (Q613) Static ports are usually fitted to both sides of the aircraft fuselage. This will:

- o A: reduce the position error.
- B: balance out errors caused by side slipping or yawing.
- o C: enable a greater number of instruments to be fitted.

318: (Q320) When a hydraulic lock condition in a jack occurs, what happens to the hydraulic flow?

- o A: no flow, but jack continues to move under gravity.
- B: no flow, jack is stationary.
- o C: flow, but no movement.

319: (Q78) If a wave has a velocity of 4800 meter per second and a wave-length of 5 meter, what is the frequency of the wave?

- o A: 9,6 kHz
- o B: 0,96 MHz
- C: 960 Hz

320: (Q91) Which irregular variation in ionospheric conditions can cause a waiting period of several days before communications return to normal?

- A: Ionospheric storms.
- o B: Sudden ionospheric disturbance.
- o C: Sporadic E

321: (Q623) A thermocouple type thermometer consists of....

- o A: two metal conductors of the same type connected at two points.
- o B: a Wheatstone bridge connected to a voltage indicator.
- C: two metal conductors of different type welded together at one point.

322: (Q668) In a direct reading compass, horizontality is achieved by....

- o A: changing the magnet system in a liquid-filled bowl.
- B: using pendulous suspension.
- o C: using jeweled bearings.

323: (Q249) During the take-off mode the outflow valves are in the pre-pressurisation position. How do the outflow valves move?

- o A: In the modulating mode.
- o B: Move to open position.
- C: Move towards closed.

324: (Q606) What are the inputs to the ADC ? 1. OAT. 2. Dynamic pressure. 3. TAT. 4. Static pressure. 5. Vertical speed. 6. Pitot pressure.

- A: 3, 4 and 6.
- o B: 1, 2, 5 and 6.
- o C: 3, 4, 5 and 6.

325: (Q746) The In-seat audio and video channels and volume can be selected and adjusted by the passenger using the....

- o A: IFES SC (In-flight Entertainment System System Controller).
- o B: IFES AMCU (Advanced Master Control Unit).

- C: IFES PCU (passenger control unit).

326: (Q338) The cam plate in a nose undercarriage is ...

- o A: part of the shimmy damper.
- B: to centre the nose wheels for gear retraction.
- o C: for alignment of the nose wheel steering on nose undercarriage extension.

327: (Q509) Which one of the following is an advantage of a Microwave Landing System (MLS) compared with an Instrument Landing System (ILS)?

- o A: The installation does not require to have a separate method (marker beacons or DME) to determine range.
- B: It is insensitive to geographical site and can be installed at sites where it is not possible to use an ILS.
- o C: There is no restriction on the number of ground installations that can be operated because there is an unlimited number of frequency channels available.

328: (Q250) In a modern electronic pressurization system, what happens if the automatic cabin pressure controller fails?

- A: The crew has to control the cabin pressure manually.
- o B: The pressurization system is inoperable and the aircraft must descend to a lower altitude.
- o C: The standby cabin pressure controller takes over.

329: (Q139) The sequence of entering information in a MCDU is....

- o A: IDENT - RTE - POS INIT
- o B: POS INIT - IDENT - RTE
- C: IDENT - POS INIT - RTE

330: (Q552) In a direct cable control system, what happens to the forces the pilot feels if airspeed increases?

- o A: Decrease.
- B: Increase.
- o C: Remain the same.

331: (Q212) Why does the engine bleed air supply come from the low and high stage of the compressor?

- A: If the low pressure stage cannot supply enough air, the high stage will be used.
- o B: Some bleed air systems will use only the low pressure stage, others will use the high stage.
- o C: If the low pressure stage supply fails, the high stage takes over.

332: (Q101) Attenuation is....

- o A: the increase of power of a radio signal.
- B: the loss of power of a radio signal.
- o C: the combination of multiple radio signals.

333: (Q542) Where are the gust suppression pressure transducers located? On both sides of....

- A: the vertical stabilizer to measure the pressure differences between the sides of the tail.
- o B: the aircraft (nose and tail) to measure the pressure differences between the nose and tail (slip).
- o C: the horizontal stabilizer to measure the pressure differences between the bottom and top side of the stabilizer.

334: (Q527) The means of interacting with cabin management computers may involve using remote control devices. What do these remote devices use for communication?

- A: Either infrared (IR) or radio frequency (RF).
- o B: Ethernet.
- o C: VLF.

335: (Q299) Pressure refuelling is carried out at....

- o A: 20 PSI.
- B: 40 PSI.
- o C: 100 PSI.

336: (Q341) Why must the nose wheel assembly be centered before retraction?

- o A: The aircraft may swerve on the next landing if the nose wheel is not centered.
- B: Damage to the gear or frame structure may occur if it is not centered.
- o C: The tires may be damaged on landing if the nose wheel is not centered

337: (Q537) What is the fundamental difference between a trim tab and a servo tab?

- A: The purpose of a trim tab is to reduce continuous stick force to zero, a servo tab only reduces stickforce.
- o B: A trim tab is automatically adjusted when the particular control surface moves, a servo tab is moved independently of the particular control surface.
- o C: The functioning of a trim tab is based on aerodynamic balancing, a servo tab in general is adjusted via a screw jack.

338: (Q26) Aerodynamic speeds vary all the way from low subsonic to hypersonic. The limits of high subsonic speed range are

- o A: 1.2 to 5 M
- B: 0.3 to 0.8 M
- o C: 0.8 to 1.2 M

339: (Q460) In an Autoland, autothrottle is disengaged

- o A: manually after landing.
- o B: after a fixed period of the time after landing.
- C: after reverse thrust is applied.

340: (Q554) A yaw damper is....

- o A: an elevator augments to avoid nose-down effect at speeds greater than  $M = 0.8$ .
- B: a rudder damper designed to avoid the "dutch roll".
- o C: an elevator augments.

341: (Q415) A duplex SAS (Stability Augmentation System) architecture ensures that a lane failure results in....

- A: only a passive failure, that is, the output of the two lane actuators remains at the position it was in at the time of failure.
- o B: a passive failure with the system reverting to manual operation.
- o C: a setting which limits the movement of the two lane actuators.

342: (Q270) Some aircraft are fitted with 2 types of fire bottles: dump and metered bottles, used in the cargo compartment. Why is this?

- o A: To extinguishing different types of fires.
- o B: To ensure there is enough extinguishing agent for the whole aircraft.
- C: To ensure the concentration of extinguishing agent remains high enough for 180 minutes.

343: (Q423) The flare manoeuvre may be controlled by signals from

- o A: the glide slope receiver.
- o B: the localiser receiver.
- C: radio altimeter.

344: (Q461) During autoland all autopilot channels will disconnect in....

- o A: dual-dual system.
- o B: triplex system.
- C: duplex system.

345: (Q553) An artificial feel system is required for....

- o A: direct cable systems.
- B: power operated control systems.
- o C: power assisted control systems.

346: (Q295) In what position is the fuel crossfeed valve, when it is not used?

- A: the closed position.
- o B: the open position.
- o C: its last position.

347: (Q123) The MIDDLE MARKER of an Instrument Landing System (ILS) facility is identified audibly and visually by a series of:

- o A: dots and a white light flashing.
- B: alternate dots and dashes and an amber/yellow light flashing.
- o C: dashes and an amber light flashing.

348: (Q517) Doppler operates on the principle that .(1)..between a transmitter and receiver will cause the received frequency to .(2)..if the transmitter and receiver are moving .(3)..

- A: (1) relative motion - (2) decrease - (3) apart.
- o B: (1) the distance - (2) increase - (3) at the same speed.
- o C: (1) apparent moving - (2) decrease - (3) together.

349: (Q596) The case of an airspeed indicator is fed with:

- o A: Pitot pressure only.
- o B: Dynamic pressure only.
- C: Static pressure only.

350: (Q254) Ditching control is used for.....

- o A: deploying life rafts.
- o B: rapidly aircraft depressurisation.
- C: closing all valves and inlets.

351: (Q156) Which of the following lists all the parameters that can be determined by a GPS receiver tracking signals from 4 different satellites?

- A: Latitude, longitude, altitude and time.
- o B: Latitude, longitude and altitude.
- o C: Latitude and longitude.

352: (Q741) This is a(n).... (See the figure)

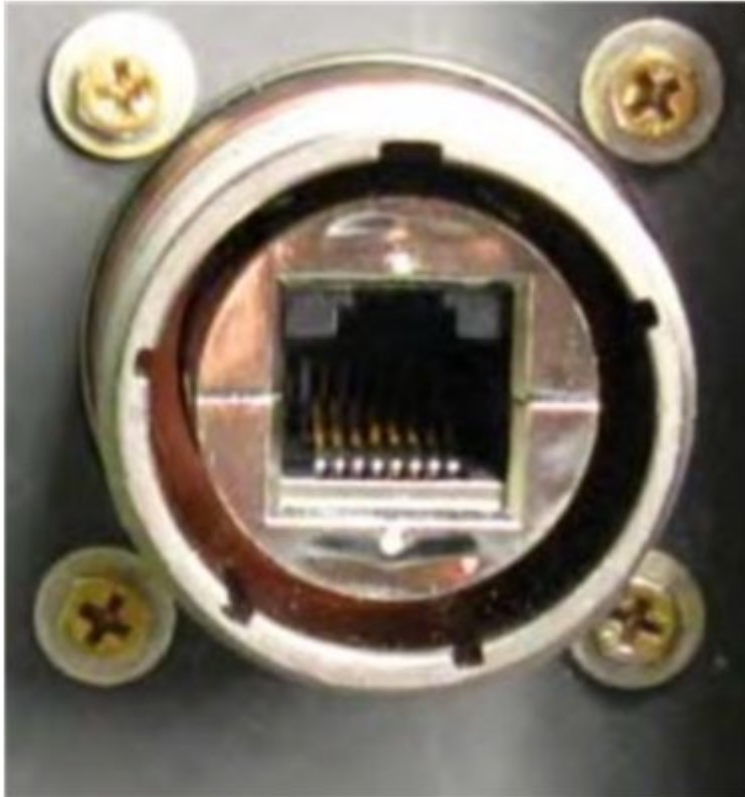

• A: Ethernet port.

- o B: QuadraX port.
- o C: RJ45 port.

353: (Q369) What is important about the air entering a dry air pump?

- o A: It must be pressure controlled.
- o B: It must be temperature controlled.
- C: It must be filtered.

354: (Q308) A hydraulic accumulator is charged with initial air pressure of 1000 PSI . When the hydraulic system pressure of 3000 PSI is reached, the air pressure is ...

- o A: 1000 PSI.
- B: 3000 PSI.
- o C: 4000 PSI.

355: (Q82) An increase in the frequency of a radio wave will have what effect, if any, on the velocity of the radio wave?

- A: None.
- o B: Increase.

o C: Decrease.

356: (Q171) What type of generator / alternator is used in a variable speed constant frequency system?

- o A: Brushless alternator.
- B: DC alternator.
- o C: DC generator.

357: (Q95) A measurement of the voltage to current ratio ( $V_{in}/I_{in}$ ) at the input end of a transmission line is called the

- A: input impedance.
- o B: voltage-gain ratio.
- o C: input-gain rate.

358: (Q179) What powers the hydraulic motor generator (HMG)?

- o A: RAT hydraulic pump.
- o B: Hydraulic hand pump.
- C: Main hydraulic system.

359: (Q749) The inflight entertainment equipment is connected to ...

- A: the ODN (Open Data Network) of the Core network system.
- o B: the IDN (Isolated Data Network) of the Core network system.
- o C: its own network system, completely isolated from the Core network system.

360: (Q731) For IMA, a faster and duplex data communication protocol was required than the ARINC 429 standard. The new standard is ..

- o A: ARINC 429 duplex.
- B: ARINC 664.
- o C: AFDX (Avionics Full Duplex).

361: (Q707) Access to the Central Maintenance Computers is through....

- o A: a control box.
- o B: a press-to-test switch on the computer itself.
- C: the line select keys on the CDU.

362: (Q533) When an aircraft fitted with spoilers is rolled to the left, what is the movement of those spoilers?

- o A: Right spoiler is deflected down.
- B: Left spoiler is deflected up.
- o C: Left spoiler is deflected up and the right down.

363: (Q142) When power is applied to the FMS, the CDU shows the....

- A: ident page.
- o B: route (RTE) page.
- o C: climb (CLB) page for take-off.

364: (Q81) What will be the effect on the wavelength of radio wave if the frequency increases? The wavelength....

- o A: is not influenced.

- o B: will increase.
- C: will decrease.

365: (Q440) When can the FMS be engaged with the autothrottle?

- o A: With either the Flight Director or the Digital Control System (DFCS) engaged.
- B: only after take off.
- o C: only with the Flight Director selected.

366: (Q281) Does the pressure in a fire bottle vary with the temperature?

- A: Yes.
- o B: Only when the temperature is lower than 10 degrees C.
- o C: It has no influence on the pressure in a fire bottle.

367: (Q242) The outflow valve of a pressurized cabin system opens when the cabin pressure is....

- A: too high.
- o B: too low or too high.
- o C: too low.

368: (Q479) A mode C transponder

- o A: can be used for TCAS on ILS approach only.
- o B: can be used for TCAS II.
- C: cannot be used for TCAS II.

369: (Q350) Inadvertent retraction of an electronically controlled landing gear on the ground is....

- o A: not possible because the system is not powerful enough.
- B: prevented by the ground/air logic system.
- o C: always a danger after the ground locks have been removed.

370: (Q275) What does the red indicator disk on the fuselage indicate?

- o A: Indicates that the fire bottle has been fired.
- o B: Indicates that the fire bottle has not thermally discharged.
- C: Indicates a thermal discharged of the fire bottle.

371: (Q86) The density of ionized layers is normally greatest during which of the following periods?

- o A: At night.
- B: Between early morning and late afternoon.
- o C: Between afternoon and sunset.

372: (Q587) The function of the accelerometer in the IVSI is....

- o A: to enable the instrument to be used at bank angles in excess of 40°.
- o B: to damp' the system during rapid alternating height changes.
- C: to give immediate response to vertical departures from horizontal flight.

373: (Q53) What is the benefit of using a semi-monocoque construction?

- o A: no safety factor is required
- B: provides a stronger construction than a monocoque.
- o C: does not require rivetting.

374: (Q269) On a 'Pull-and-turn' fire switch, when is the fire bottle discharged?

- A: By pulling the handle up and turning the handle to left or right.
- o B: By pulling the handle up, turning it to one side and pressing the discharge button.
- o C: By pulling the handle up.

375: (Q728) The standardized Real-Time Operating system used in IMA uses the.....

- o A: RTOS specification.
- o B: ARINC 429 specification.
- C: ARINC 653 specification.

376: (Q439) With autothrottle selected in the SPEED MODE compatible autopilot modes are

- o A: VOR ARM and HDG HOLD.
- B: IAS HOLD and ALT ARM.
- o C: V/S and ALT ARM.

377: (Q557) When does a stick-shaker comes into operation? When the aircraft....

- o A: goes supersonic.
- o B: is approaching the 'critical mach number'.
- C: is approaching a stall.

378: (Q237) What determines the effective temperature of a cabin?

- A: Temperature and humidity.
- o B: Temperature, humidity, thermal inertia and heat load.
- o C: Temperature only.

379: (Q197) In the differential protections circuit in the figure below, what type of transformers would be TRANSFO 1 and TRANSFO 2?

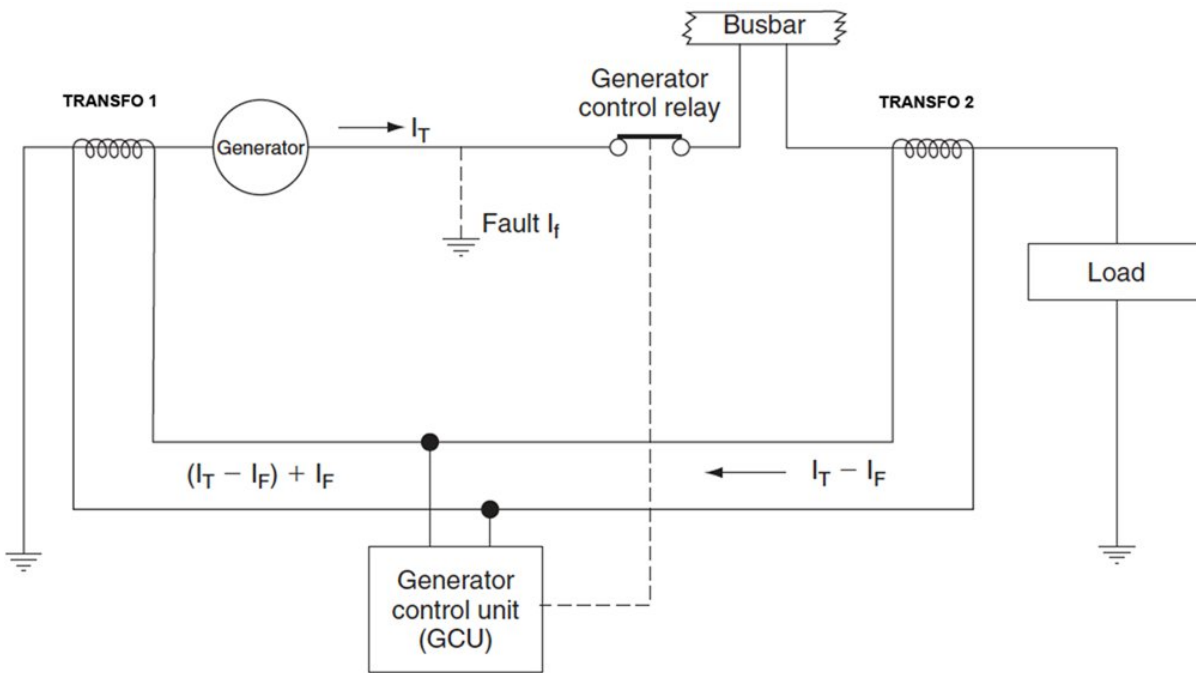

- A: Both are current transformers

- o B: TRANSFO 1 is a current transformer, TRANSFO 2 is a voltage transformer
- o C: Both are voltage transformers

380: (Q530) How does the IFES (In-Flight Entertainment System) send audio and video signals?

- A: A standard 100 Mbit/s fast Ethernet LAN.
- o B: A standard 1 Gbit/s fast Ethernet LAN.
- o C: Fibre optics.

381: (Q562) The velocity of sound at the sea level in a standard atmosphere is:

- A: 661 kts.
- o B: 644 kts.
- o C: 332 kts.

382: (Q334) On large aircraft, what are bogie type undercarriages used for?

- o A: Absorb increased landing shock.
- B: Spread the weight over a large area.
- o C: Prevent skidding.

383: (Q513) Hyperbolic propagation errors are....

- o A: the greatest above water.
- B: the greatest above land.
- o C: not present in this type of navigation.

384: (Q232) Temperature control of cabin air is achieved by....

- o A: controlling the speed of the air cycle machine.
- o B: varying the ambient airflow to the heat exchanger.
- C: regulating the amount of hot air added to the conditioned air.

385: (Q375) On an autopilot coupled approach, GO AROUND mode is engaged:

- A: By the pilot pushing a button located on the throttles.
- o B: By the pilot selecting G.A. mode on the flight mode control panel.
- o C: If the aircraft reaches the decision height selected on the radio altimeter at a higher speed than the one selected.

386: (Q737) Airplane system data critical to flight are connected to the..... In the Core Network System.

- A: Isolated Data Network (IDN).
- o B: Open Data Network (ODN).
- o C: Common Data Network (CDN).

387: (Q209) The external emergency lights are used for:

- A: Illuminating the escape slides.
- o B: Illuminating the area around the aircraft to help rescue workers.
- o C: Identifying the entry doors to help rescue workers locate them.

388: (Q357) How does an 'on board oxygen generation system' (OBOGS) produce oxygen?

- A: By using molecular filters.
- o B: By using sodium chloride.
- o C: By electrolysis of water.

389: (Q394) In the FMS vertical navigation (V NAV) climb mode the throttles are used for

- o A: correction minor speed deviations.
- o B: controlling to a maximum thrust.
- C: maintaining a computed EPR.

390: (Q682) WXR display is on:

- o A: the co-pilots screen only.
- o B: the captains screen only.
- C: on both the captains and co-pilots screens.

391: (Q294) What is the purpose of the check valve fitted to a fuel jettison system?

- o A: prevent the centre from being defueled.
- o B: automatically stop the fuel jettison operation after a period of time.
- C: prevent the dumping of the outer tanks.

392: (Q465) During a CAT 2 ILS automatic approach, the source for altitude information is the

- o A: basic altitude capsule stack.
- B: radar altimeter which becomes effective below about 2500 feet.
- o C: mode comparator sensor.

393: (Q358) In which type of aircraft is liquid oxygen used?

- o A: Most large passenger aircraft.
- B: Military aircraft.
- o C: Aircraft flying at very high altitudes.

394: (Q199) What is 'no breaks power transfer'?

- A: Power supply is transferred from one source to another without interrupting the supply.
- o B: Power supply is transferred from one source to another while bypassing the circuit breakers.
- o C: Power supply remains with the same source even though power transfer to another source has been selected.

395: (Q491) The data supplied by a radio altimeter:

- o A: is used by the automatic pilot in the altitude hold mode.
- o B: is used only by the radio altimeter indicator.
- C: indicates the distance between the ground and the aircraft.

396: (Q642) The artificial horizon uses:

- A: a gravity controlled gyro.
- o B: a horizontally controlled gyro.
- o C: a rate or restrained gyro.

397: (Q58) What is ATA Zone 100?

- o A: upper fuselage.
- o B: vertical fin.
- C: lower fuselage.

398: (Q376) A full operational autopilot system will ensure that

- A: the aircraft will continue its automatic landing in the event of a single failure.
- o B: the automatic pilot will automatically cause the aircraft to overshoot if any failure is detected.
- o C: the automatic pilot will automatically disengage whenever any failure is detected.

399: (Q54) What are the main longitudinal members in a fuselage called?

- o A: frames.
- o B: spars.
- C: longerons.

400: (Q572) What will result if the instrument static pressure line becomes disconnected inside a pressurized cabin during cruise flight?

- o A: The altimeter and airspeed indicator will both read high.
- B: The altimeter and airspeed indicator will both read low.
- o C: The altimeter will read low and the airspeed indicator will read high.

401: (Q462) In triplex autoland system failure of one channel will

- o A: disconnect all channels.
- o B: disconnect the failure channel and continue with a manual approach.
- C: disconnect the failure channel and continue autoland approach.

402: (Q184) Which of the following is NOT part of a three-unit voltage regulator?

- o A: Current limiter.
- o B: Reverse current relay.
- C: Open phase protection.

403: (Q657) Deviation compensation in a flux gate compass is done:

- o A: Automatically within the compass system.
- o B: Mechanically.
- C: Electronically.

404: (Q120) What is the glide slope frequency range?

- o A: 108 - 112 Mhz.
- o B: 108 - 112 Ghz.
- C: 329 - 335 Mhz.

405: (Q84) Electrically charged particles that affect the propagation of radio waves are found in what atmospheric layer?

- A: Ionosphere.
- o B: Troposphere.
- o C: Stratosphere.

406: (Q392) With the autopilot engaged in the ALT mode the Captain alters the barometric setting. The aircraft:

- o A: trips out of altitude hold.
- o B: changes its altitude in accordance with the change in pressure setting.
- C: maintains its altitude.

407: (Q504) ACARS messages are sent from the aircraft via:

- o A: an UHF communication transceiver.
- o B: GNSS.
- C: a VHF communication transceiver.

408: (Q145) If there is no (navigation) radio updating, what effect will this have on the FMS?

- o A: this FMS will automatically update the system.
- o B: this will have no effect on the FMS.
- C: this may cause the FMS to deviate from the desired track.

409: (Q697) Stall warning will be given at speeds....

- o A: higher than stall speed.
- o B: at the actual stall speed.
- C: lower than stall speed.

410: (Q5) A jet aircraft equipped with inboard and outboard ailerons is cruising at its normal cruise Mach number. Which of the following conditions is correct?

- A: only the inboard ailerons are active.
- o B: only the outboard ailerons are active.
- o C: the inboard and outboard ailerons are active.

411: (Q259) What type of fire detection system is a fenwal detection system?

- A: Continuous loop system.
- o B: Thermocouple system.
- o C: Spot system.

412: (Q442) If during take off (auto throttle engaged) the auto throttle fails, then....

- o A: Status light illuminates.
- o B: Auto pilot disengages.
- C: Throttle hold is annunciated.

413: (Q709) Where is the loaded software held?

- A: CMC (Central Maintenance Computer) storage device, ready to be reinstalled should something happen that corrupts a particular program.
- o B: In a centralized maintenance cabinet, ready to be send and reinstalled should something happen that corrupts a particular program.
- o C: On the flight deck, ready to be reinstalled should something happen that corrupts a particular program.

414: (Q48) What happens to the RPM of the rotor, when lifting the collective lever during an autorotative descent?

- A: reduce.
- o B: increase.
- o C: remain the same.

415: (Q305) Accumulators as fitted to aircraft hydraulic systems ...

- A: store fluid under pressure.
- o B: are only ever used in an emergency.
- o C: provide additional fluid if leaks occur.

416: (Q417) The purpose of Automatic Trim function in autopilot is to....

- o A: tell the pilot when elevator trimming is required.
- B: control elevator trim tab in order to relieve elevator load.
- o C: trim throttles to obtain smooth engine power variation.

417: (Q71) Skin effect is most likely to occur:

- A: at the higher frequencies i.e. VHF and above.
- o B: at high power levels up to VHF.
- o C: in radar systems fed by rectangular waveguides.

418: (Q434) The auto throttle system is: 1. able to catch and maintain the N1 RPM. 2. able to catch and maintain the N2 RPM. 3. able to catch and maintain an airplane indicated airspeed IAS. 4. always engaged automatically at the same time as the autopilot. The combination regrouping all the correct statements is:

- A: 1 and 3.
- o B: 1 and 4.
- o C: 2 and 3.

419: (Q309) What is the reason for pressurizing the hydraulic reservoirs?

- A: minimize the possibility of pump cavitation.
- o B: maintain a constant fluid level.
- o C: provide a reserve of stored energy.

420: (Q112) New ELT s will transmit on ..... so that the signal can be picked up by the Search and Rescue satellite network.

- A: 406.025 MHz
- o B: 121.5 MHz
- o C: 108.10 MHz

421: (Q336) What is the function of a fusible plug in an aircraft wheel rim?

- o A: As overpressure protection.
- B: As overtemperature protection.
- o C: To deflate the tyre before removal.

422: (Q288) What must be fitted to an automatic refueling system?

- o A: fuel crossfeed system.
- B: protection against overfill.
- o C: vents to allow overfueling.

423: (Q690) The level of alert for conditions that require immediate flight crew awareness and immediate flight crew response is..... Loss of cabin pressure or an engine fire are typical examples.

- o A: a caution.
- B: a warning.
- o C: alert message.

424: (Q46) Where is the helicopter throttle hand grip located?

- A: collective lever.

- o B: cyclic stick.
- o C: throttle box.

425: (Q691) The following are time-critical warnings: 1. terrain awareness warnings. 2. overspeed warnings. 3. wind shear warnings. 4. TCAS resolution advisory. 5. low energy warnings. The combination regrouping all the correct time-critical warnings is:

- o A: 1, 2 and 3.
- B: 1, 2, 3, 4 and 5.
- o C: 2, 3 and 4.

426: (Q473) A 'resolution advisory' (RA) is represented on the display system of the TCAS 2 (Traffic Collision Avoidance System) by a....

- A: solid red square.
- o B: blue or white full lozenge.
- o C: red full circle.

427: (Q247) During take-off the outflow valve is selected to ....

- A: fully open.
- o B: modulating mode.
- o C: fully closed.

428: (Q56) Safe-life is

- A: the minimum number of flying hours that should elapse before a major structural failure occurs.
- o B: the sharing of loads between adjacent members.
- o C: the maximum number of flying hours that should elapse before a major structural failure occurs.

429: (Q21) When an aircraft fitted with spoilers is rolled to the left, what is the movement of the spoilers?

- o A: left spoiler is deflected up and the right down.
- B: left spoiler is deflected up.
- o C: left upper spoiler up and left lower spoiler down.

430: (Q763) Data on the USB keys (for data loading) is stored under the ...

- o A: ARINC 629 format.
- o B: ARINC 429 format.
- C: ARINC 615A format.

431: (Q506) MLS installations notified for operation, unless otherwise stated, provide azimuth coverage of....

- o A: +or - 20° about the nominal course line out to a range of 20 NM.
- o B: +or - 20° about the nominal course line out to a range of 30 NM.
- C: +or - 40° about the nominal course line out to a range of 20 NM.

432: (Q445) The purpose of Auto Throttle is:

- o A: automatic shut down of one engine at too high temperature.
- o B: to deactivate manual throttles and transfer engine control to Auto Pilot
- C: to maintain constant engine power or airplane speed.

433: (Q621) The white sector of the arc of a temperature gauge corresponds to:

- o A: a special operating range.
- B: a normal operating range.
- o C: an exceptional operating range.

434: (Q662) The Ground Proximity Warning systems mode 4 is activated when

- o A: When the aircraft is significantly below its ILS glidepath.
- o B: An excessive height loss is experienced after take-off during go-around.
- C: An unsafe clearance situation is experienced, with the aircraft not in the landing configuration.

435: (Q488) Modern low altitude radio altimeters emit waves in the following frequency band:

- o A: HF (High Frequency).
- o B: UHF (Ultra High Frequency).
- C: SHF (Super High Frequency).

436: (Q291) How would you shut-off the low pressure fuel supply to the engine for the purpose of engine removal?

- A: pull the fire shut-off handle.
- o B: close the HP fuel lock.
- o C: close the cross bleed valve.

437: (Q118) The Cockpit Voice Recorder of an aircraft of 5700 kg or less will always store the :

- o A: last 60 minutes.
- o B: last 120 minutes.
- C: last 30 minutes.

438: (Q630) In a capacitive fuel gauging system an increase in fuel level would:

- o A: increase capacitive reactance.
- B: increase capacitance.
- o C: decrease capacitance.

439: (Q79) Which of the following statements about a wave is the law of reflection?

- o A: The angle of incidence is not equal to the refracted wave.
- o B: The angle of incidence is equal to the refracted wave.
- C: The angle of incidence is equal to the angle of reflection.

440: (Q753) Which unit serves as the direct interface with the air-to-ground narrow band or broadband equipment and provides extensive audio, video and cached web content?

- A: The FS (file server).
- o B: The ADB (Area Distribution Box).
- o C: The AMCU (Advanced Master Control Unit).

441: (Q503) ARINC 429 SDI word format is at bits

- A: 9 - 10
- o B: 31 - 32
- o C: 1 - 8

442: (Q706) One of the advantages of the OMS (Onboard Maintenance System) is ...

- o A: to replace the tech log.
- o B: to help the pilots do a minor maintenance task.
- C: to detect and report failure.

443: (Q518) Due to 'Doppler' effect an apparent decrease in the transmitted frequency, which is proportional to the transmitter's velocity, will occur when the transmitter....

- o A: and receiver move towards each other.
- o B: moves toward the receiver.
- C: moves away from the receiver.

444: (Q743) What are the three functional domains of IMA (Integrated Modular Avionics)?

- A: Cockpit, cabin and utilities.
- o B: Flight, navigation and systems.
- o C: Ground, flight and transit.

445: (Q714) Information updates to the airborne system and communications between the ground based and airborne systems are accomplished ...

- A: through the Gate-link concept.
- o B: automatically by update from the ECAM.
- o C: by an aircraft engineer updating the system either by a floppy disc, a CD or even a hard disk.

446: (Q363) How can you see if a chemical oxygen generator has been expended?

- A: By a coloured band of thermal paint.
- o B: By a pressure indicator.
- o C: By a pop-out indicator.

447: (Q605) An air data computer (ADC) obtains altitude from....

- o A: Radio Altimeter.
- o B: GPS Satellite.
- C: Barometric data from static source.

448: (Q98) An antenna that can be mounted to radiate rf energy either vertically or horizontally is classified as which of the following types?

- A: Hertz.
- o B: Quarter-wave.
- o C: Marconi.

449: (Q561) Density varies:

- o A: inversely with pressure and directly with temperature.
- B: directly with pressure and inversely with temperature.
- o C: directly with temperature and pressure.

450: (Q168) How do you call the component that completes the magnetic circuit between the poles in a DC generator?

- o A: The armature.
- B: The yoke.
- o C: The brushes.

451: (Q283) When should you use water-type portable fire extinguishers?

- o A: Water-type portable extinguishers are perfect solid combustible materials even metal fires. (ex: brakes and magnesium wheels). Do not use them on flammable liquid fires.
- o B: Water-type portable extinguishers can be used for every fire.
- C: Water-type portable extinguishers are best for solid combustible fires (paper, fabrics, wood etc.). Never use them on electrical or flammable liquid fire.

452: (Q138) A basic RNAV system will determine tracking information from....

- A: VOR/DME.
- o B: twin DME.
- o C: Twin VOR.

453: (Q97) Energy is transmitted from a transmitter into space using which of the following devices?

- o A: a receiver.
- o B: a delay time.
- C: an antenna.

454: (Q459) An aircraft will capture the auto land system at

- o A: 3500 ft.
- o B: 2500 ft.
- C: 1500 ft.

455: (Q114) When activated, the battery of an ELT must be capable of furnishing power for signal transmission for at least ...

- o A: 28 days.
- o B: 24 hours.
- C: 48 hours.

456: (Q228) What is the benefit of injecting water in the ram air duct?

- o A: Make the cabin air less dry.
- B: Improve the efficiency of the heat exchanger.
- o C: Cool the air cycle machine.

457: (Q272) Where is the lavatory waste bin fire extinguisher localized?

- o A: There is no extinguisher in the lavatory.
- B: Is usually located above the waste bin.
- o C: In lavatory ceiling.

458: (Q366) What is the main advantage of using compressed air over hydraulics or electrical systems?

- A: Compressed air is lightweight and since no return system is required, weight is saved.
- o B: 3000 PSI (210 bar) is at all times available, even with small leaks.
- o C: Pneumatic operations are almost 100 percent efficient, with only negligible loss due to air friction.

459: (Q588) The purpose of the IVSI is to:

- o A: compensate for the change of pressure when initiating a climb or descent.
- o B: instantaneously indicate to the pilot when an aircraft pitches, especially in steep turns.

- C: give an instantaneous indication of the aircraft's vertical speed when a climb or descent has been initiated.

460: (Q284) When should you use halon-type portable fire extinguishers? The halon-type portable fire extinguisher may be used....

- o A: on solid materials combustibile materials only.
- B: for every kind of fire. In the cabin it will be used for fires coming from electrical equipment.
- o C: only for fuel fires. (All fuel types)

461: (Q352) On aircraft with bogie beams (trucks), what is used to detect air/ground?

- o A: Weight-on-wheel switches.
- B: Truck tilt switches.
- o C: Squat switches.

462: (Q267) A systron-Donner fire detection system uses.....

- A: helium gas.
- o B: air.
- o C: nitrogen gas.

463: (Q154) What is the pseudo-random code used by all civilian GPS users?

- A: the C/A code.
- o B: the P code.
- o C: the Y code.

464: (Q40) What is the ability of the rotor blade to move up and down called?

- o A: feathering.
- o B: dragging.
- C: flapping.

465: (Q189) What is the primary function of a current transformer in an aircraft?

- A: Measure current in an electrical circuit.
- o B: Step-up the current in a circuit.
- o C: Measure voltage in an electrical circuit.

466: (Q353) What is the result when the steel target is in close proximity to the proximity sensor?

- o A: An open switch.
- B: A closed switch.
- o C: A failed switch.

467: (Q122) The aircraft DME receiver is able to accept replies to its own transmissions and reject replies to other aircraft interrogations because:

- A: pulse pairs are discreet to a particular aircraft.
- o B: transmission frequencies are 63 MHz different for each aircraft.
- o C: pulse pairs are amplitude modulated with the aircraft registration.

468: (Q178) In a constant speed motor generator, what powers the generator?

- o A: An electric motor powered by the battery.
- o B: An electric motor powered by the RAT generator.

- C: A hydraulic motor powered by a hydraulic pump driven by the RAT.

469: (Q153) GPS sends different codes, what are these codes?

- o A: P code only.
- B: C/A code and P (precision) code.
- o C: C/A (coarse/acquisition) code only.

470: (Q187) Emergency lighting is part of which service?

- o A: Essential.
- B: Vital.
- o C: Ground.

471: (Q567) Pitot pressure is a combination of:

- A: Static pressure and dynamic pressure.
- o B: Static pressure and position error.
- o C: Dynamic pressure and position error.

472: (Q51) What is a damage tolerant design?

- A: allows for certain damage to the structure to go un-repaired between scheduled maintenance.
- o B: is applied only to secondary structure.
- o C: allows for damage to structure but loses its structural strength.

473: (Q324) A serrated rotor ice detector provides warning of ice by ...

- o A: decreased torque caused by ice formation slowing the rotating wheel and illuminating a warning light in the cockpit.
- o B: ice formation stopping the rotation of a rotary knife edge and illuminating a warning light in the cockpit.
- C: increased torque caused by ice formation slowing the rotating wheel and illuminating a warning light in the cockpit.

474: (Q39) What happens to the drag, when the angle of attack is increased on a main rotor blade?

- o A: there is no change in drag.
- B: there is an increase in drag.
- o C: there is a reduction in drag.

475: (Q586) The IVSI is:

- o A: only unreliable at angles of bank exceeding 55°.
- o B: Unreliable in pitch but reliable in roll.
- C: Unreliable in unbalanced turns/angles of bank exceeding 40°.

476: (Q312) A constant volume hydraulic system uses a(n).... to relieve pressure in the system when no services are being used?

- o A: Pressure relief valve.
- o B: return line back to pump.
- C: ACOV (Automatic Cut Out Valve).

477: (Q301) What is the purpose of longitudinal balance fuel systems?

- A: Keep the center of gravity as close as possible to the ideal position.

- o B: Trim the aircraft so that there is no need for trimmable horizontal stabilizers.
- o C: Carry more fuel.

478: (Q773) Which communication system let the flight crew request and obtain information about meteorological parameters (weather, wind, visibility, clouds,.....)?

- o A: FANS (Future Air Navigation Systems).
- B: ATIS (Automatic Terminal Information System).
- o C: Automatic Dependent Surveillance Broadcast

479: (Q599) The Machmeter has two capsules:

- o A: one responds to altitude, the other to density.
- o B: 'one responds to airspeed, the other to the local speed of sound.'
- C: one responds to altitude, the other to airspeed.

480: (Q202) Where will you find taxi lights?

- A: On the nose landing gear.
- o B: In the wing leading edges.
- o C: In the wing root.

481: (Q362) A green disk on the side of the fuselage is missing, what does this indicate?

- o A: The oxygen bottle pressure is below operational limits.
- o B: The maximum pressure in the oxygen supply lines has been exceeded.
- C: The maximum pressure in the oxygen cylinder has been exceeded.

482: (Q223) When the ram air passes through the primary heat exchanger, where does the ram air in a turbo-fan cold air system flows to?

- A: Via large fan to ram air outlet.
- o B: Turbine.
- o C: Inter cooler or secondary heat exchanger.

483: (Q27) Critical Mach Number ( $M_{crit}$ ) is:

- A: The Mach number at which sonic flow is first achieved.
- o B: The Mach number at which shock waves are formed at the leading edge of the airfoil.
- o C: The Mach number at which compressibility effects first appear.

484: (Q74) Radio-frequency waves cannot be seen for which of the following reasons?

- o A: Because radio-frequency waves are above the sensitivity range of the human eye.
- o B: Because radio-frequency energy is low powered.
- C: Because radio-frequency waves are below the sensitivity range of the human eye.

485: (Q106) Satisfactory two-way VHF communication can typically be maintained up to ..... miles, this range dependent on the aircraft height.

- o A: 2000
- o B: 20
- C: 200

486: (Q446) In order to know in which mode the autothrottles are engaged, the crew will check the:

- A: PFD (Primary Flight Display).

- o B: ND (Navigation Display).
- o C: throttles position.

487: (Q402) During approach, roll out mode occurs....

- o A: at alert height.
- B: after flare.
- o C: before flare.

488: (Q602) The purpose of the altitude alert system is to generate a visual and aural warning to the pilot when the:

- A: airplane altitude differs from a selected altitude.
- o B: proximity to the ground becomes dangerous.
- o C: altimeter setting differs from the standard setting above the transition altitude.

489: (Q541) Which control surfaces may be used by active load control?

- o A: Elevator and stab.
- o B: Aileron and spoiler.
- C: Elevator and aileron.

490: (Q192) Transformer rectifiers are used for:

- o A: Converting DC into AC.
- B: Converting AC into DC.
- o C: Boosting the output voltage from 28V to 110V.

491: (Q326) Which system supplies air for anti-icing of the wings?

- A: engine compressors.
- o B: air conditioning ducting.
- o C: a combustion heater.

492: (Q722) Which system can also be used to monitor the aircraft's structure and thus identify any faults before they cause catastrophic failure.

- o A: the Electronic library system.
- o B: the CDU (Control Display Unit).
- C: the Flight Data Recorder.

493: (Q181) The ram air turbine will supply....

- o A: three phase DC power.
- B: single phase AC power.
- o C: DC power.

494: (Q229) What is the function of a pack control valve?

- o A: Control the outlet temperature of the pack.
- o B: Control the airflow out of the cabin.
- C: Control the air flow into the cabin.

495: (Q591) During an approach to land at an airfield with the pitot source blocked, the Air Speed Indicator will show:

- A: an increasing under read.

- o B: No change in the indication.
  - o C: an increasing over read.
- 496: (Q231) A large aircraft air conditioning system's cabin temperature control....
- o A: all zone temperatures are controlled from one master switch.
  - B: is selectable for each zone individually from the flight deck.
  - o C: involves modulating the pack valve.
- 497: (Q618) An airspeed indicator has....
- o A: static connection only.
  - o B: pitot connection only.
  - C: pitot and static connection.
- 498: (Q190) Which of the following statements about current transformers is true?
- o A: Current transformers always have a square transformer core.
  - o B: The primary winding should never be left open when in operation.
  - C: The secondary winding should never be left open when in operation.
- 499: (Q99) A complete antenna system consists of which of the following components?
- A: A feeder line, a coupling device, and an antenna.
  - o B: A feeder, a coupling device, and a transmitter.
  - o C: An antenna, a transmission line, and a receiver.
- 500: (Q274) How can you determine if the lavatory fire bottle has been discharged?
- A: By weighing it.
  - o B: By reading the pressure gauge on the bottle.
  - o C: By the temperature indicator strip.
- 501: (Q673) The Flight Data Recorder actually starts running:
- A: before the a/c starts moving under its own power.
  - o B: when a/c lines up on runway.
  - o C: at the beginning of the T/O run.
- 502: (Q742) The ARINC 664 Ethernet uses ...
- o A: a high speed, two way, multiple terminal digital data bus operating at 2 megahertz.
  - o B: a pair of twisted wires with shielding around them for full duplex operation at 2 megahertz.
  - C: two twisted wire pairs or quad cables as the transport medium for full duplex operation at 100 megabits per second.
- 503: (Q65) What types of nuts must be used for bonding connections?
- o A: Nylon self locking nuts.
  - B: Self locking nuts of all metal construction.
  - o C: Nuts must not be used for bonding.
- 504: (Q398) The two parameters used for category aircraft classification are....
- o A: radio height/runway visual range.
  - o B: localiser and glideslope.
  - C: decision height and runway visual range.

505: (Q443) When GA is initiated?

- o A: Auto throttle remains engaged allowing pilot to control the throttles.
- o B: Auto throttle disengages at 2000 ft/min rate and wings will level.
- C: Auto throttle remains engaged giving correct G/A thrust.

506: (Q699) When a stall warning occurs, the angle of attack vane....

- A: moves up.
- o B: moves down.
- o C: moves aft.

507: (Q227) Heating for pressure cabins is obtained from....

- o A: only by adding heat electrically to the air supply.
- B: air supply heated by adding hot bleed air.
- o C: air cycle machine.

508: (Q409) When the aircraft nose yaws to the left, the yaw damper will apply corrective rudder to

- A: the right.
- o B: the left with some aileron assistance.
- o C: the left.

509: (Q252) What places the pressure controller in the depressurisation mode after landing?

- o A: Engines at idle.
- o B: Landing gear compression.
- C: Engines at idle and the landing gear compressed.

510: (Q565) The pressure probe used to measure the pressure of a low pressure fuel pump is:

- o A: a capacitor.
- B: a Bourdon tube.
- o C: a bellows sensor.

511: (Q546) A Fowler flap....

- o A: does not change the wing area.
- o B: decreases wing area.
- C: increases wing area.

512: (Q702) A vibration meter measures the....

- o A: frequency in Hz.
- B: amplitude at a given frequency.
- o C: period in seconds.

513: (Q170) What type of voltage regulator is shown in the figure below?

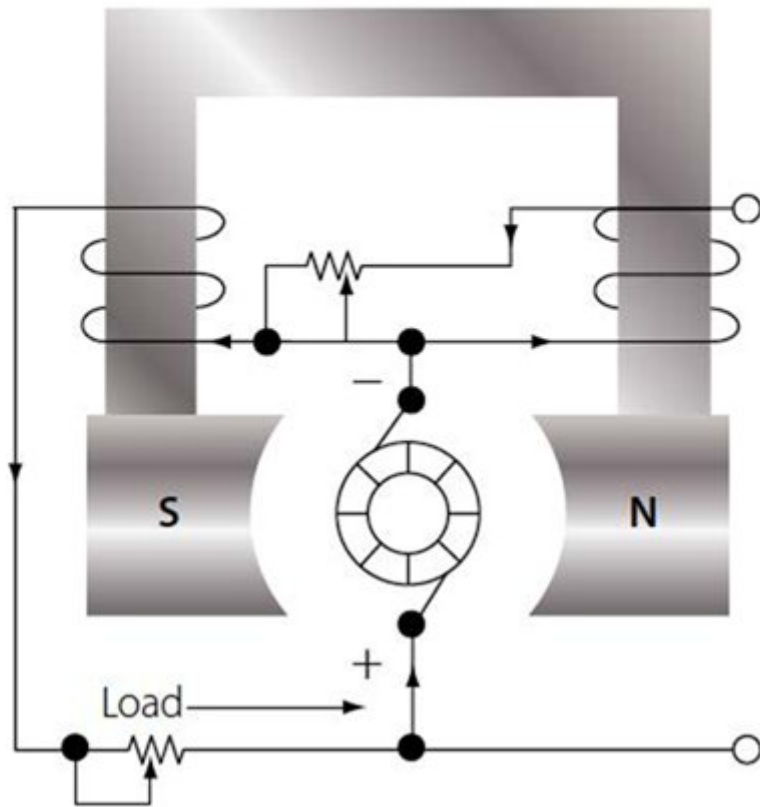

(A)

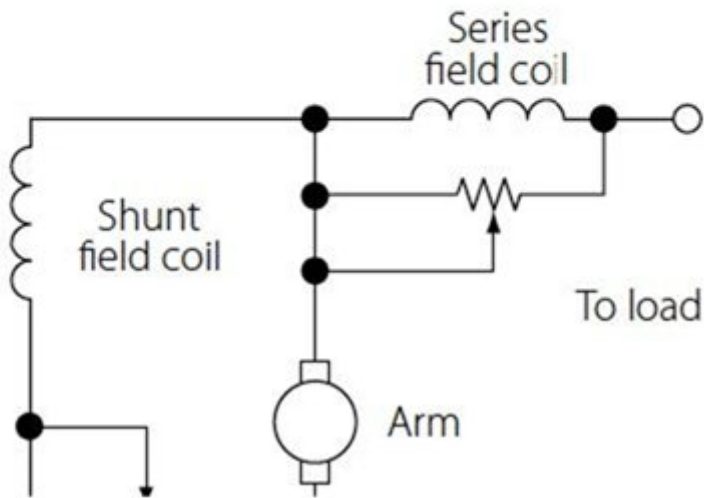

• A: Compound

wound generator.

- o B: Parallel wound generator.
- o C: Series wound generator.

514: (Q396) Overshoot or go-around mode can be initiated

- o A: at any time.

- B: only when the auto-approach mode is activated.
- o C: at any time after autoland has been engaged.

515: (Q663) The Ground Proximity Warning systems mode 5 is activated when

- o A: An excessive height loss is experienced after take-off during go-around.
- B: When the aircraft is significantly below its ILS glidepath.
- o C: An unsafe clearance situation is experienced, with the aircraft not in the landing configuration.

516: (Q665) If the GPWS (Ground Proximity Warning System) activates, and alerts the pilot with an aural warning 'DON'T SINK' (two times), it is because:

- o A: the aircraft experiences an unexpected proximity to the terrain, with landing gear retracted.
- o B: the aircraft experiences an unexpected proximity to terrain, without landing-flap selected.
- C: during take-off or missed approach maneuver, the aircraft has started to loose altitude.

517: (Q656) The purpose of the slaving torque motor is:

- o A: To send heading information to the compass card in the heading indicator.
- o B: To ensure that the gyro wheel maintains sufficient speed to stay rigid in space.
- C: To produce a precessive force in order to align the gyro with the earth's magnetic field.

518: (Q389) The Altitude Select System:

- A: Is annunciated by light and/or sound when airplane is approaching selected altitude.
- o B: Engages autopilot Auto Trim at selected altitude.
- o C: Disengages autopilot Auto Trim at selected altitude.

519: (Q315) What allows a hand pump, which is normally a single cylinder, to operate as a double acting pump?

- o A: relief valve.
- o B: piston ram displacement.
- C: two non-return valves fitted.

520: (Q583) In a servo-assisted altimeter, the secondary winding from the E-bar provides an electrical current direct to the:

- o A: two phase motor.
- o B: capsule stack.
- C: amplifier of the servomotor..

521: (Q300) In case of a CG control system failure, the computer switches automatically to an alternate mode. What will happen?

- o A: jettison of the fuel in the trim tank.
- o B: stops fuel transfer from or to the trim tank.
- C: the trim tank will be directly used to feed the engines..

522: (Q303) What is the purpose of a check valve?

- A: allows fluid to flow only in one direction.
- o B: prevents pump cavitation.
- o C: prevents overpressure.

523: (Q222) What is the function of the turbine in an air cycle machine? The turbine drives the compressor to....

- A: increase temperature.
- o B: decrease temperature.
- o C: pressurise aircraft.

524: (Q169) The output of a single coil generator is

- o A: a flat line.
- B: a sine-wave.
- o C: a saw foot.

525: (Q536) What must you do to yaw the aircraft to the right?

- o A: The left rudder pedal is pushed forward and the rudder moves to the left.
- o B: The right rudder pedal is pushed forward and the rudder moves to the left.
- C: The right rudder pedal is pushed forward and the rudder moves to the right.

526: (Q111 )Emergency locator transmitters are self-contained, self-powered radio transmitters, designed to transmit a signal on the international distress bands of ..... (civilian) and ..... (military).

- o A: 108.10 MHz - 112 MHz
- o B: 30 MHz - 300 MHz
- C: 121.5 MHz - 243 MHz

527: (Q406) Inputs to the rudder channels initially originate from

- A: compass gyro and turn and slip gyro.
- o B: AH (altitude hold) gyro and turn and slip gyro.
- o C: servomotors.

528: (Q458) If a fault is detected during an autoland approach the system will totally disconnect if it is a

- o A: Duplex system.
- o B: Triplex system.
- C: Simplex system.

529: (Q246) What are the basic flight deck indications for pressurization?

- o A: Cabin altitude, ambient temperature and pressure differential.
- o B: Aircraft altitude, rate of climb and atmospheric pressure.
- C: Cabin altitude, cabin rate of climb and pressure differential.

530: (Q128) Transmissions from VOR facilities may be adversely affected by....

- o A: night effect.
- B: uneven propagation over irregular ground surfaces.
- o C: static interference.

531: (Q578) Density errors are the result of variations in atmospheric....

- A: pressure and temperature.
- o B: temperature only.
- o C: pressure only.

532: (Q64) How should all electronic equipment bondings be installed in the aircraft structure?

- o A: With a low current path to the airframe structure.
- o B: With a high impedance path to the airframe structure.
- C: With a low impedance path to the airframe structure.

533: (Q330) What must you be aware of when testing pitot head heaters?

- o A: They can only be checked by noting the rate of temperature rise of the probe.
- B: They must only be switched on for the minimum time required to check serviceability.
- o C: They should be switched on for five minutes to allow to stabilise before taking ammeter readings.

534: (Q319) What is the purpose of a mechanical sequence valve?

- o A: ensure the correct operation of brake anti-skid units.
- B: ensure the correct sequence of landing gears and doors.
- o C: ensure the correct function of safety switches.

535: (Q348) What controls the nose wheel steering on a large modern aircraft?

- A: A separate pilot operated control.
- o B: Differential braking
- o C: The control column.

536: (Q604) An encoding altimeter is a....

- o A: combined altimeter and airspeed indicator.
- B: pneumatic altimeter that sends a digital code to the ATC transponder.
- o C: full digital altimeter.

537: (Q766) A pre-departure clearance or PDC is given to the pilots via....

- A: an ACARS message.
- o B: the datalink system.
- o C: voice (from ATC).

538: (Q258) What protects the aircraft from over-pressurization?

- o A: The outflow valve.
- o B: Cabin pressure controller.
- C: The positive pressure relief valve.

539: When activated, the ELT transmits : 1. a standard swept tone on 121.5 MHz. 2. a standard swept tone on 243.0 MHz. 3. a 5 watt encoded digital message to the COSPAS/SARSAT satellite system. 4. a 24 bit address through the Mode S transponder.

- A: 1, 2 and 3.
- o B: 1, 2 and 4.
- o C: 1 and 4.

540: (Q556) How can flutter be reduced?

- o A: A horn balance.
- B: Mass balancing.
- o C: Servo tabs.

541: (Q316) Where is the high pressure filter in a hydraulic system fitted?

- o A: in the return line to the reservoir.

- o B: downstream of the reservoir.
- C: downstream of the pump.

542: (Q158) The satellites (GPS) provide: position, time data and....

- o A: flightplan.
- o B: distance from departure.
- C: velocity.

543: (Q183) How is voltage regulation achieved on DC generators? By changing the....

- o A: generator speed.
- B: field current.
- o C: field voltage.

544: (Q760) Which part of the avionics domain of the network server system gives a single way of communication, preventing malicious data coming going to the avionics domain?

- o A: secure communication interface.
- o B: ethernet gateway module.
- C: open world diode.

545: (Q166) What is the purpose of a rectifier?

- o A: Convert the DC output into AC.
- B: Convert the AC output to DC.
- o C: Control the output voltage of a parallel wound generator.

546: (Q724) Waste water drain mast....

- o A: are heated to a high temperature in the air and on ground.
- B: are heated to a lower temperature with the aircraft on ground.
- o C: are not heated.

547: (Q380) The command bars of a flight director are generally represented on an:

- A: ADI (Attitude Director Indicator).
- o B: HSI (Horizontal Situation Indicator).
- o C: RMI (Radio Magnetic Indicator).

548: (Q431) The take-off of an aircraft is....

- o A: not possible with go-around (GA) set on the trust mode control panel (TMCP).
- o B: flown automatically.
- C: flown manually.

549: (Q234 )Conditioned air is...

- A: temperature and pressure adjusted.
- o B: oxygen added.
- o C: moisture removed.

550: (Q489) During the approach, a crew reads on the radio altimeter the value of 650ft. This is an indication of the true height of the....

- o A: aircraft with regard to the ground at a given barometric pressure.
- B: lowest wheels with regard to the ground at any time.

o C: aircraft with regard to the runway.

551: (Q435) At the missed approach point the TOGA switch on the throttles is depressed. Which of the following statements are correct: 1. Pilot selects maximum power. 2. Auto-throttle selects GA power. 3. Aircraft automatically cleans up. 4. Auto-pilot flies the GA. 5. Pilot flies the GA manoeuvre The combination regrouping all the correct statements is:

- A: 2 and 4
- o B: 1 and 4
- o C: 1 and 5

552: (Q62) Fuselage station numbers are measured from the front of the aircraft. In what unit are they measured?

- o A: feet.
- B: inches.
- o C: feet and inches.

553: (Q244) The constant-differential pressure operation mode cabin is when the cabin altitude....

- o A: remains the same as the flight altitude.
- B: is maintained at a constant amount above the outside ambient air pressure.
- o C: remains constant as the flight altitude changes.

554: (Q512) Hyperbolic navigation systems determine present position from the intersection of....

- A: lines of position.
- o B: longitudinal magnetic field lines.
- o C: GPS satellite intersection.

555: (Q29) To increase critical Mach number

- o A: tailerons are fitted.
- o B: elevons are fitted.
- C: the wings are swept.

556: (Q427) The application of normal forces on the control column with the autopilot engaged is called....

- o A: parallel connected system.
- B: control wheel steering.
- o C: touch control steering.

557: (Q177) Which of the following statements about the ram air turbine is false?

- A: The RAT can deploy automatically on the ground.
- o B: The RAT can be deployed manually.
- o C: The RAT can sometimes also supply hydraulic power.

558: (Q408) The purpose of a yaw damper is to

- A: block the Dutch roll frequency.
- o B: produce a coordinated turn.
- o C: assist the aerodynamic response.

559: (Q343) When the landing gear is selected up the sequence of lights is....

- o A: red, green, out.
- o B: out, red, green.
- C: green, red, out.

560: (Q110) The Selcal (Selective Calling) can be used by....

- A: VHF and HF systems.
- o B: VHF system only.
- o C: HF system only.

561: (Q205) Which lights are located in the passenger service units?

- o A: Flood lights.
- B: Spotlights.
- o C: Cabin emergency lights.

562: (Q695) The angle of attack transmitter provides an electric signal varying with: 1. the angular position of a wind vane. 2. the deviation between the airplane flight attitude and the path calculated by the inertial unit. 3. a probe differential pressure depending on the variation of the angle of attack. The combination regrouping all the correct statements is:

- o A: 1 and 2.
- o B: 2 and 3.
- C: 1 and 3.

563: (Q387) An autopilot closed loop control....

- o A: has no feedback data.
- B: is controlled by the AP mode control unit.
- o C: is for stabilisation only.

564: (Q383) A single axis autopilot may also be called:

- A: wing leveller.
- o B: auto stabilisation loop.
- o C: altitude hold.

565: (Q764) Which system enables aircraft to be accurately tracked by air traffic controllers and other pilots without the need for conventional radar?

- o A: FANS (Future Air Navigation System).
- o B: Mode S transponder.
- C: ADS-B (Automatic Dependent Surveillance Broadcast).

566: (Q711) A FMS navigation database is updated

- o A: at the operators request.
- o B: once a month.
- C: every 28 days.

567: (Q653) The directional gyro keeps its rotation axis aligned toward:

- o A: Geographic North.
- B: A point in space.
- o C: Magnetic North.

568: (Q516) The best fix for hyperbolic navigation is when the lines of position (LOP) intersect....

- o A: in a diagonal angle.
- o B: at the greatest curve.
- C: at an angle of 90o.

569: (Q216) What supplies the warm air in a Bleed air air-conditioning system?

- o A: The gas turbine exhaust.
- o B: The engine exhaust heat.
- C: The compressor of the gasturbine engine.

570: (Q105) The mode of operation of the VHF comms transceiver is

- o A: double channel duplex.
- B: single channel simplex.
- o C: single channel duplex.

571: (Q708) When a..... is displayed, the aircraft is considered unserviceable (only specific failures are permitted to exist as stated in the MEL).

- A: Status Message.
- o B: Maintenance Message.
- o C: Fault Code.

572: (Q582) In the next figure of a servo altimeter the components labeled A, B and C in order are:

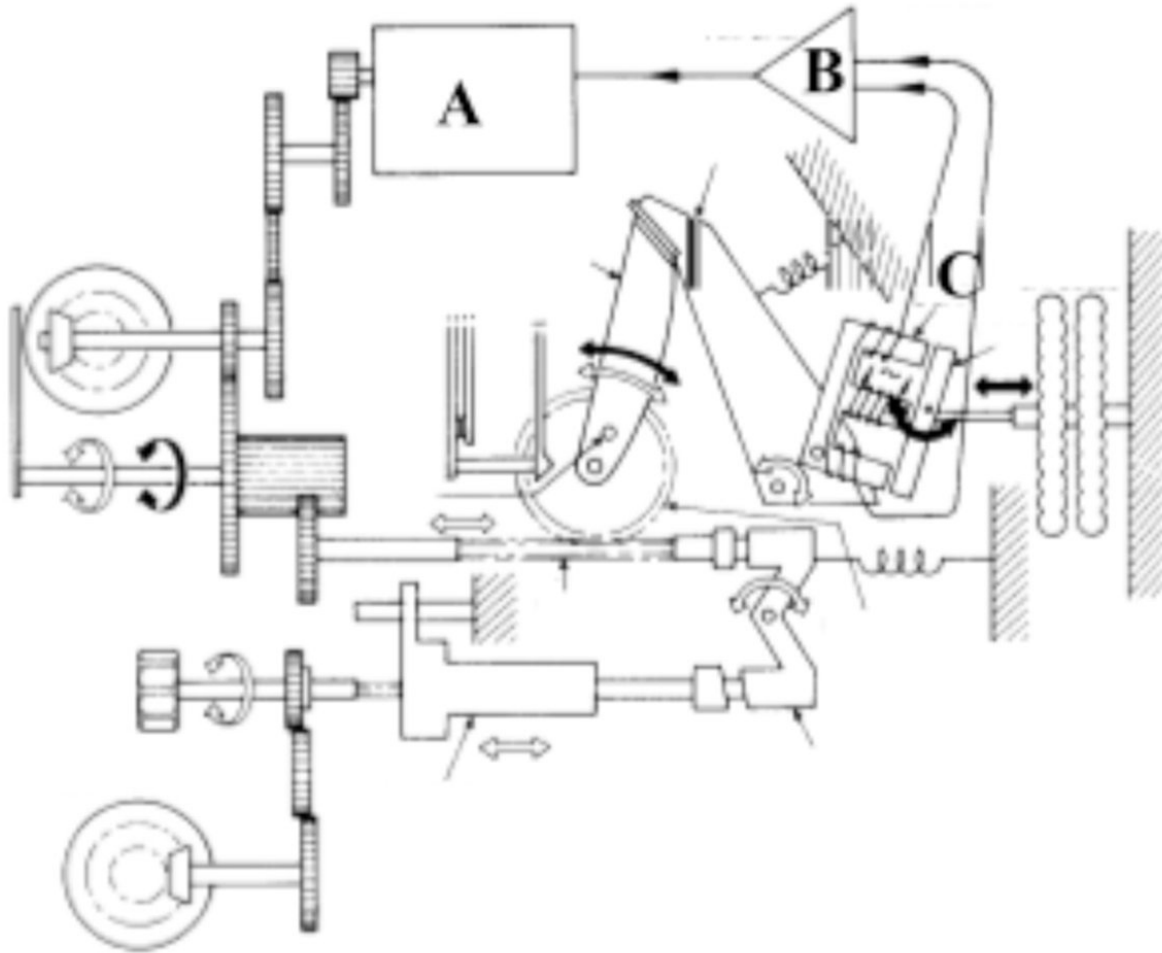

- o A: torque motor - inductive pick-off - amplifier
- B: two way motor - amplifier - inductive pick-off
- o C: torque motor - amplifier - transducer

573: (Q155) What is the minimum number of satellites required for a Satellite-Assisted Navigation System (GNSS/GPS)?

- o A: 2
- B: 4
- o C: 3

574: (Q720) A permanent monitoring of the vertical acceleration (G-force) of an aircraft during landing is a part of....

- o A: the 'Low Cycle Fatigue Counter'.
- o B: the 'HUMS' (Health and Usage Monitoring System).
- C: the 'Damage Tolerance Monitoring'.

575: (Q649) The rotor of a rate gyroscope is over speeding. The pilot carries out a turn with the rate gyroscope indicating RATE 1. The actual rate of turn will be:

- o A: 3° per second.
- o B: more than 3° per second.

- C: less than 3° per second.

576: (Q579) If the static source to an altimeter becomes blocked during a descent, the instrument:

- A: Continues to show the height at which the blockage occurred.
- o B: Will over-read by a constant amount.
- o C: Will progressively under-read.

577: (Q456) Purpose of an autoland decrabbing manoeuvre is to

- o A: assist with glide slope tracking.
- B: point the aircraft down the runway at touch down.
- o C: assist with localiser tracking.

578: (Q595) IAS is adjusted to CAS by the application of:

- o A: compressibility error.
- B: instrument and pressure error.
- o C: density error.

579: (Q747) Which discretises provides the PSEU (Proximity Switch Electronics Unit) to the IFES SC (In-Flight Entertainment System Controller)?

- A: Air/ground discrete; parking brake discrete; start take-off roll discrete; nose landing gear discrete.
- o B: Air/ground discrete; IRS (Inertial Reference System) position discrete; ADC (Air Data Computer) discretises (Airspeed, Ground speed, Mach number, altitude).
- o C: Air/ground discrete; air speed discrete; altitude discrete, GPS position discrete.

580: (Q748) Each Ethernet station is given a 48-bit address. How are the first two fields called?

- A: Source/destination Identifier (SDI).
- o B: Country Code.
- o C: Parity Bit.

581: (Q200) When connecting external power, what prevents the application of reverse polarity to a DC powered aircraft?

- o A: A reverse current switch.
- o B: An irreversible external power connector (fool proof).
- C: A reverse polarity diode.

582: (Q83) The bending of a radio wave because of a change in its velocity through a medium is known as....

- A: refraction.
- o B: reflection.
- o C: diffraction.

583: (Q620) Direct reading aircraft thermometer usually consists of a bimetallic element protruding into the airstream. Movement of the pointer over the temperature scale will depend on:

- o A: increase in pressure as airspeed increases.
- o B: difference in electrical resistance of the two metals.
- C: different coefficients of expansion of the two metals.

584: (Q477) The TCAS (Traffic Collision Avoidance System) is a proximity alarm system which detects a 'traffic' when the conflicting traffic is equipped with a:

- A: serviceable mode S or SSR transponder.
- o B: SELCAL system.
- o C: DME system.

585: (Q622) The sensors used to measure the exhaust gas temperature on an airplane equipped with turbojets are:

- o A: Capacitors whose capacity varies proportionally with temperature.
- o B: Based on metallic conductors whose resistance increases linearly with temperature.
- C: Thermocouples.

586: (Q574) Which instruments are connected to the aircraft pitot-static system?

- A: vertical speed indicator, altimeter and airspeed indicator.
- o B: turn-and-slip indicator, airspeed indicator and directional gyro (air operated).
- o C: turn coordinator, cabin altimeter and cabin rate-of-change indicator.

587: (Q628) The capacitor gauge principle is based on:

- o A: variation of the EMF in a Wheatstone bridge.
- o B: variation of capacitance by volume measure at the probe.
- C: variation of capacitance of a capacitor with the nature of the dielectric.

588: (Q570) Pressure errors which can be calculated and presented graphically in the aircraft manual include:

- A: Position and configuration errors.
- o B: Position and maneuver errors.
- o C: Configuration, maneuver and turbulence errors.

589: (Q502) In an ARINC 429 wordstring, bits 1 to 8 represent the

- A: information contained in the data word.
- o B: source of message.
- o C: destination LRU address.

590: (Q61) What are water lines?

- o A: Vertical measurement lines.
- B: Horizontal measurement lines.
- o C: Measurements from the centre line.

591: (Q323) What causes ice formation on wings?

- A: supercooled water changing state on contact with the wing.
- o B: suspended ice crystals melting on contact with the wing and instantly re-freezing.
- o C: ice crystals forming layers on contact with the wing.

592: (Q419) The purpose of an airplane automatic trim system is to trim out the hinge moment of the :

- A: elevator(s).
- o B: elevator(s) and rudder(s).
- o C: elevator(s), rudder(s) and ailerons.

593: (Q455) The order of autoland approach is

- o A: LOC, GS, FLARE, ATT HOLD
- B: LOC, GS, ATT HOLD, FLARE
- o C: GS, LOC, ATT HOLD, FLARE

594: (Q240) How is the pressure inside the cabin controlled?

- o A: By controlling the amount of bleed air to the air conditioning packs.
- o B: By regulating the air conditioning pack output pressure.
- C: By using one or more outflow valves.

595: (Q487) A radio altimeter can be defined as a....

- o A: self-contained on-board aid used to calculate the barometric altitude of the aircraft.
- B: self-contained on-board aid used to measure the true height of the aircraft.
- o C: ground radio aid used to measure the true altitude of the aircraft.

596: (Q484) Airborne Weather Radar is an example of..... radar operating on a frequency of..... in the.....band.

- o A: secondary - 9375 MHz - SHF
- B: primary - 9375 MHz - SHF
- o C: secondary - 9.375 MHz - UHF

597: (Q6) When ailerons are deployed, what happens to the drag? Drag increases on....

- A: the up going wing.
- o B: the down going wing.
- o C: both wings.

598: (Q640) The inner gimbal assembly of an attitude indicator is pivoted..(1)..... in the...(2).....

- A: (1) to give freedom - (2) pitch plane.
- o B: (1) longitudinally - (2) rolling plane.
- o C: (1) longitudinally - (2) outer gimbal.

599: (Q650) The principle of operation of the turn and bank indicator is best described as:

- A: a single gimbal gyroscope in which a spring, opposing the primary precession, in turn produces a secondary precession equal to the aircraft rate of turn.
- o B: a single gimbal gyroscope whose primary precession is opposed by a spring which, in turn, produces a second precession equal and opposite the aircraft rate of turn.
- o C: an earth gyro in which a calibrated spring ensures the tilt of the gyro is proportional to the aircraft rate of turn.

600: (Q725) How are drinking water pipes prevented from freezing?

- o A: Placing the pipes adjacent to hot water piping.
- o B: Installation of neoprene foam insulation.
- C: Wrapping the pipes with heated tapes or blankets.

601: (Q535) What happens when you move the aileron control to the right?

- o A: the right elevator goes up and the left down.
- o B: the right aileron moves up and the left down.
- C: the right aileron moves down and the left up.

602: (Q438) An automatic throttle, engaged in the EPR mode, will control

- o A: the aircraft altitude to maintain constant engine input pressure.
- B: the engine throttles to maintain a constant engine power setting.
- o C: the engine throttles to maintain a constant acceleration rate.

603: (Q730) Which LRU is the interface between the aircraft systems and the ARINC network remote switches and convert network data to the appropriate format.

- A: Remote Data Concentrators.
- o B: ARINC 664 remote switches.
- o C: AFDX switches.

604: (Q134) Every dot on the localizer deviation scale is....

- o A: 5 nm from center line
- B: 1 nm from center line
- o C: 10 nm from center line

605: (Q50) Which of the following is an example of a failsafe structure?

- o A: Nose radome.
- o B: Single stringer.
- C: Multiple Spars.

606: (Q43) How does collective control input affect the pitch of the blades?

- o A: increases the angle on the advancing blade and reduces it on the retreating one.
- B: increases the pitch angle the same amount on all blades.
- o C: increases the angle on the retreating blade and reduces it on the advancing one.

607: (Q37) What will the advancing blade do during forward flight?

- A: flap up.
- o B: flap down.
- o C: lag.

608: (Q17) When a Leading edge flap is fully extended, what is the slot in the wing for?

- A: To re-energise the boundary layer.
- o B: To increase the lift.
- o C: To allow the flap to retract into it when it retracts.

609: (Q493) A Radar altimeter system measures altitude....

- o A: in combination with GPS-satellites
- o B: in relation to sea level.
- C: above terrain.

610: (Q507) Which one of the following methods is used by a Microwave Landing System (MLS) to indicate distance from the runway threshold?

o A: Timing the interval between the reception of sequential secondary radar pulses from the MLS station to the aircraft.

- B: A DME co-located with the MLS transmitters.
- o C: Measurement of the frequency shift between the MLS azimuth and elevation transmissions.

611: (Q42) Which movement can each individual blade of a semi-rigid rotor system make independently?

- A: flap and change pitch.
- o B: flap only.
- o C: flap, change pitch and drag.

612: (Q560) Which of the following instruments are navigation instruments? 1. air speed indicator. 2. altimeter. 3. gyro horizon. 4. global navigation satellite system. 5. Inertial reference system.

- A: 4 and 5.
- o B: 1, 2 and 3.
- o C: 3, 4 and 5.

613: (Q359) The pressure regulator on an oxygen demand system regulates the pressure to:

- o A: 400 PSI
- o B: 90 PSI
- C: 70 PSI

614: (Q102) The VHF (very high frequency) range of the radio spectrum is the band extending from

- o A: 3 to 30 GHz
- B: 30 MHz to 300 MHz.
- o C: 300 to 3000 MHz.

615: (Q466) With localizer capture, the EFIS indication is VOR/LOC in....

- o A: white letters.
- B: green letters.
- o C: amber letters.

616: (Q677) The displays marked A, B, C and D are respectively: (See the figure)



**A**

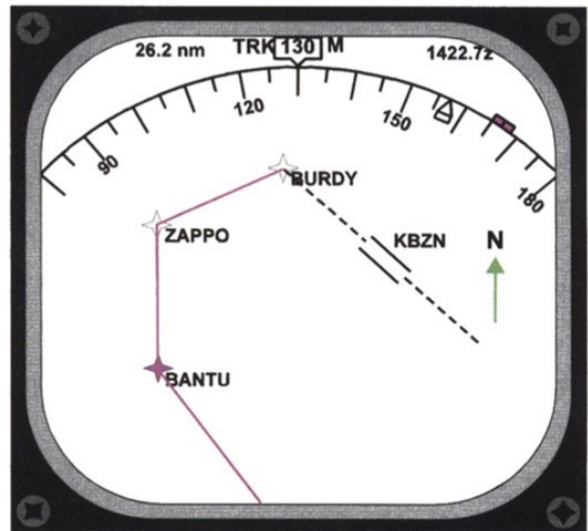

**B**



**C**



**D**

- o A: A. VOR - B. ILS - C. NAV - D. Plan
- o B: A. MAP - B. VOR - C. ILS - D. Plan
- C: A. NAV - B. PLAN - C. VOR - D. ILS

617: (Q129) In a Doppler VOR (DVOR) the reference signal is ... (1) ..., the bearing signal is ... (2) ... and the direction of rotation of the bearing signal is ... (3) ...

- o A: (1) AM - (2) FM - (3) clockwise.
- B: (1) AM - (2) FM - (3) anti-clockwise.
- o C: (1) FM - (2) AM - (3) clockwise.

618: (Q585) As a result of a blocked static vent during a rapid climb, the VSI displays:

- o A: an over-reading of the rate of climb.
- o B: the correct rate of climb.

- C: zero rate of vertical speed.

619: (Q356) What is the chemical used in chemical oxygen generators?

- o A: Ozone
- o B: Sodium hydroxide
- C: Sodium chlorate and iron

620: (Q712) The FMS is updated

- o A: automatically by update from the ACARS.
- B: by an aircraft engineer updating the system either by a floppy disc, a CD or even a hard disk.
- o C: by the aircrew by reference to the Tech Log.

621: (Q726) What type of valve is the toilet tank drain valve?

- o A: Spring loaded open.
- B: Spring loaded closed.
- o C: Not spring loaded.

622: (Q266) In a continuous loop fire detection system is the Kidde system a....

- A: thermistor type.
- o B: bi-metallic spot type.
- o C: pneumatic type.

623: (Q756) The information signs are controlled from the cabin configuration software inside the....

(See the figure)

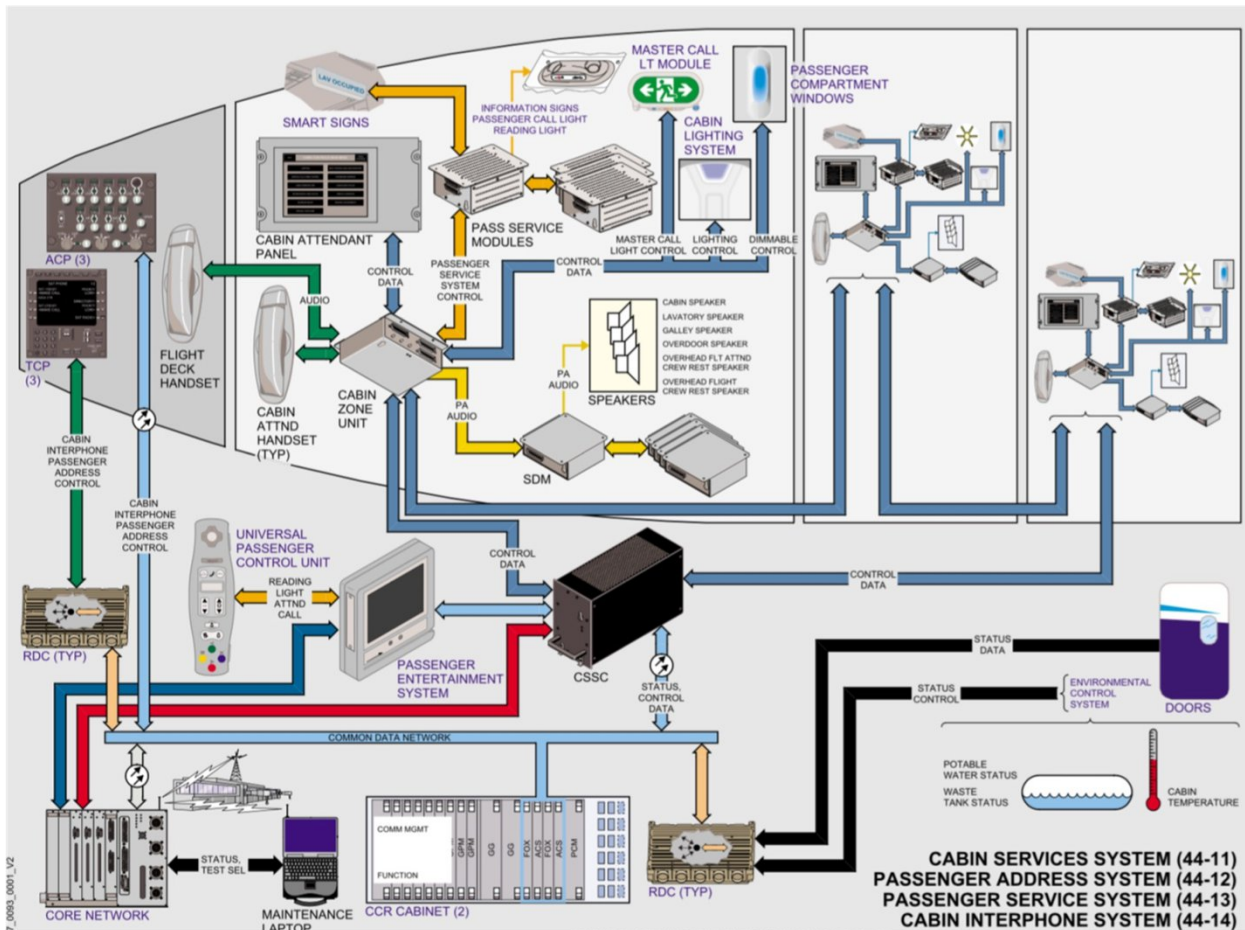

- o A: Cabin Attendant Panel.
- o B: Passenger Control Unit.
- C: Cabin Services System Controller.

624: (Q769) Which system (of the core network system) collects, correlates, stores and shows fault information for most airplane systems.

- o A: crew information system.
- o B: common data network (CDN).
- C: central maintenance computing function.

625: (Q664) If an aircraft is flying (with flaps and landing gear retracted) in proximity to terrain and its GPWS (Ground Proximity Warning System) get activated, because it is detecting that the airplane has an excessive rate of descent, the system provides the following aural warning signals:

- o A: ... TERRAIN, TERRAIN ... followed by ... WHOOP WHOOP PULL UP ... (twice).
- B: ...SINK RATE, SINK RATE ... followed by ... WHOOP WHOOP PULL UP ... (twice).
- o C: ... TOO LOW, TERRAIN ... (twice) followed by ... TOO LOW GEAR ... (twice).

626: (Q701) In an engine vibration monitoring system for a turbojet any vibration produced by the engine is:

- o A: fed directly to the cockpit indicator without amplification or filtering.
- o B: inversely proportional to engine speed.
- C: amplified and filtered before being fed to the cockpit indicator.

627: (Q551) In which control system will an artificial feel system be required?

- o A: Aerodynamically controlled system.
- B: Power operated control system.
- o C: Power assisted control system.

628: (Q163) What happens at the end of the charge of a NiCad battery?

- o A: The battery heats up.
- o B: CO<sub>2</sub> is generated,
- C: The cell voltage drops.

629: (Q328) How and when is windshield rain repellent applied?

- o A: before rain and spread on window surface by wipers.
- o B: rubbed on the surface of the windscreen, prior to flight.
- C: during rain and spread on windows surface by wipers.

630: (Q521) Emergency lightning can be illuminated by....

- A: a guarded three position switch (ON-OFF-ARMED) in the cockpit and a Two position switch in the cabin (ON-NORMAL).
- o B: a guarded three position switch (ON-OFF-ARMED) in the cabin and a Two position switch in the cockpit (ON-NORMAL).
- o C: automatically when power is removed from the aircraft (in an emergency or by the pilots).

631: (Q474) The principle of the TCAS (Traffic Collision Avoidance Systems) is based on the use of :

- o A: air traffic control radar systems.
- B: transponders fitted in the aircraft.
- o C: airborne weather radar system.

632: (Q496) ADS-B: 1. broadcasts information about aircraft, such as identification, current position, altitude and velocity. 2. provides air traffic controllers with real-time position information. 3. receives Flight Information data. 4. receives Traffic Information Service data. 5. receives other ADS-B Out broadcasting aircraft.

- o A: 2, 4 and 5
- B: 1, 2, 3, 4 and 5.
- o C: 1, 3 and 5.

633: (Q307) Which component in a hydraulic system ensures immediate response when a service is selected?

- o A: engine driven pump.
- o B: selector.
- C: accumulator.

634: (Q279) Pushing the fire test button does not test:

- A: Squibs.
- o B: Indications and warnings.
- o C: Fire detectors.

635: (Q1) About which axis does rolling occur?

- o A: vertical axis.
- o B: lateral axis.
- C: longitudinal axis.

636: (Q47) What happens when raising the collective lever?

- o A: the pitch is decreased on all blades.
- B: the pitch is increased on all blades.
- o C: the angle of attack is decreased on the retreating blade.

637: (Q256) How is the emergency pressure control valve operated if the automatic control system fails?

- o A: Hydraulically
- o B: Electrically
- C: Manually

638: (Q759) Which item handles all of the on-demand applications available to passengers?

- A: the IFES File Server.
- o B: the IFES Crew Panel.
- o C: the IFES Advanced Master Control Unit (AMCU).

639: (Q736) Airplane system data not critical to flight are connected to the..... In the Core Network System.

- o A: Crew Wireless LAN Unit (CWLU).
- B: Open Data Network (ODN).
- o C: Common Data Network (CDN).

640: (Q600) A transport airplane has to be equipped with an altitude warning device. This system will warn the crew about : 1. getting close to the preselected altitude, during both climb and descent; 2. getting close to the preselected altitude, during climb only; 3. the loss of altitude during take-off or missed approach; 4. a wrong landing configuration; 5. a variation higher or lower than a preselected altitude. The combination regrouping the correct statements is:

- A: 1 and 5
- o B: 2
- o C: 1, 3 and 4.

641: (Q34) How does a rotor generate lift?

- o A: down-wash below the blade.
- B: low pressure above the blade.
- o C: high pressure above the blade.

642: (Q464) During a Category II automatic approach, the height information is supplied by the:

- o A: altimeter.
- B: radio altimeter.
- o C: encoding altimeter.

643: (Q67) What are used on today's aircraft to protect the avionics from lightning strikes?

- o A: Surge protection devices.
- o B: Circuit breakers with high sensitivity.
- C: Bonding wires.

644: (Q651) The errors of a DGI are: 1. Earth rate. 2. Transport wander. 3. Banking when pitched up. 4. Annual movement of poles. 5. Mechanical problems.

- o A: 3, 4 & 5.
- o B: 2, 3 & 5.
- C: 1, 2, 3 & 5.

645: (Q454) If during autoland the LOC signal is lost at 400 ft in final approach

- o A: system degrade to CAT II.
- B: go-around is initiated.
- o C: autoland is continued.

646: (Q66) What is used to protect the nose radome from lightning strikes?

- o A: The radome is composite material and does not require a special lightning protection.
- B: Lightning diverter strips.
- o C: Bonding wire.

647: (Q539) The purpose of a trim tab (device) is to....

- o A: trim the airplane at low airspeed.
- B: reduce or to cancel control forces.
- o C: to assist in steering commands.

648: (Q117) The Cockpit Voice Recorder of a large transport aircraft will always store the last....

- A: 30 minutes.
- o B: 120 minutes.
- o C: 60 minutes.

649: (Q196) Where in the circuit would a fuse be installed?

- A: As close to the power source as possible.
- o B: As close to the unit to be protected as much as possible.
- o C: Where access to replace the fuse is easiest.

650: (Q63) What is the measurement of the fuselage location along the Z-coordinate?

- o A: butt line.
- o B: fuselage station.
- C: water line.

651: (Q255) The emergency pressure control valve....

- o A: is fitted to all pressurized aircraft.
- B: is not a very refined way of controlling.
- o C: is electrically controlled.

652: (Q627) The indication of a fuel float gauge varies with: 1. Aircraft altitude. 2. Accelerations. 3. Atmospheric pressure. 4. Temperature. The combination of correct statement is:

- A: 1,2,4.
- o B: 1,2,3,4.
- o C: 1, 2.

653: (Q344) Which of the following are characteristics of a carbon brake?

- o A: have less weight than normal brake units but fade away at high temperatures.
- o B: weigh the same as normal brake units and fade away at high temperatures.
- C: have less weight than normal brake units and have increased efficiency at high temperatures.

654: (Q452) Which is the correct sequence for an autoland?

- A: Localiser capture, glideslope capture, attitude hold and flare.
- o B: Glideslope capture, altitude hold and flare.
- o C: Localiser capture, glideslope capture, flare and attitude hold.

655: (Q641) Using a compensated vacuum-driven attitude indicator during a turn....

- o A: there will be indication errors in pitch and roll.
- o B: there will be indication errors in pitch only.
- C: the indications will be corrected for a selected speed and rate of turn.

656: (Q3) When the control column is moved forward and to the right, what is the reaction of the flight control surfaces?

- A: the elevator goes down, the right aileron moves up and the left aileron moves down.
- o B: the elevator goes down, the right aileron moves down and the left aileron moves up.
- o C: the elevator goes up, the right aileron moves up and the left aileron moves down.

657: (Q776) A ventilation fan has shut-down due to an overheat condition. The crew can....

- o A: restart the fan immediately by resetting the control switch to 'off' and 'on' again.
- o B: not restart the fan in flight. Ground crew must reset the system first.
- C: restart the fan after it has cooled down.

658: (Q603) Altitude alert is when....

- o A: a decision of whether to land is made.
- o B: an alert of the ground proximity is made.
- C: an alert of the selected altitude of the aircraft is reached.

659: (Q213) Where is the ground air conditioning cart used for?

- o A: Running the de-icing system.
- B: Supplying the cabin with conditioned air, when only the cabin needs to be conditioned.
- o C: Starting the engines.

660: (Q568) Dynamic Pressure is:

- o A: Static pressure minus pitot pressure.
- B: Total pressure minus static pressure.
- o C: Pitot pressure plus static pressure.

661: (Q667) At a given place, compass deviation will:

- o A: Depend on the value of variation.
- o B: Be constant always.
- C: Vary with aircraft heading.

662: (Q410) A yaw damper will apply rudder proportional to

- o A: amount of aircraft disturbance.

- o B: attitude of aircraft.
- C: rate of yaw.

663: (Q428) Central Air Data Computers (CADC's) transmit data concerning

- A: airspeed, altitude and Mach number.
- o B: airspeed, altitude and decision height.
- o C: airspeed and altitude only.

664: (Q311) What is the purpose of a 'cut-out' valve in a hydraulic system?

- o A: is to limit loss of fluid in the event of pipe fracture.
- B: is to relieve the pump of load when the operation of services is complete and the accumulator charged with fluid.
- o C: is to prevent creep in jack operated services which have several selected positions.

665: (Q693) A stall warning system is based on a measure of:

- o A: Groundspeed.
- o B: Airspeed.
- C: angle of airflow sensor and flap position transmitter.

666: (Q433) Auto-throttle engaged mode can be checked by the pilot, using:

- A: primary flight display.
- o B: position of throttles.
- o C: thrust control computer.

667: (Q750) Data can be transferred wirelessly from the In-flight Entertainment system on the aircraft to a terminal receiving station on the ground through....

- o A: the ATIS (Automatic Terminal Information Service).
- o B: the ACR (Avionics Communication Router).
- C: the use of the GSM Cell Data Mode (CDM), also referred to as Cell Modem (CM).

668: (Q277) Why is there a strainer installed in the fire bottle discharge valve?

- o A: To catch any fragment from the bottle.
- o B: To catch the yellow disk as an indication that the fire bottle is used.
- C: To catch any fragment from the frangible disk.

669: (Q469) The special 'Ident' feature (SPI-code)....

- A: allows ATC to confirm aircraft identity.
- o B: is to confirm TCAS identity.
- o C: is to confirm SELCAL identity.

670: (Q601) An 'altitude alerting system' must at least warn the crew: 1. when approaching the pre-selected altitude; 2. when the airplane is approaching the ground too fast; 3. in case of a given deviation above or below the pre-selected altitude (at least by an aural warning); 4. in case of excessive vertical speed; 5. when approaching the ground with the gear retracted. The combination regrouping all the correct statements is:

- A: 1, 3.
- o B: 1, 3, 4.
- o C: 2, 4, 5.

671: (Q215) Which of the following bleed air sources CANNOT supply the aircraft systems in flight?

- A: Pneumatic ground cart.
- o B: Auxiliary power unit.
- o C: Engines.

672: (Q257) In case of a pneumatic duct leak, the crew must....

- o A: land immediately.
- o B: turn temperature control to full cold.
- C: isolate the faulty duct.

673: (Q437) Auto throttle can hold: 1. speed. 2. flight path. 3. altitude. 4. Mach. 5. EPR / N1. 6. Attitude. The combination regrouping all the correct statements is:

- o A: 1, 2, 3 and 4.
- o B: 1, 2 and 6.
- C: 1, 4 and 5.

674: (Q119) On an ILS approach what will cause the aircraft to fly onto the beam?

- o A: Radio deviation.
- B: Course deviation.
- o C: Glideslope deviation.

675: (Q107) A squelch circuit disables the receiver output, ....

- o A: when satcom is selected.
- o B: when a SELCAL is received from ground stations equipped with a coding device.
- C: when no signals are being received so preventing noise being fed to the crew headsets between ground transmissions.

676: (Q659) The Ground Proximity Warning systems mode 1 is activated when

- A: The barometric descent rate is excessive with respect to the aircraft height above the terrain.
- o B: An excessive height loss is experienced after take-off during go-around.
- o C: The aircraft is flying into rising terrain.

677: (Q515) What is the difference between VOR and hyperbolic navigation?

- A: VOR has straight lines and hyperbolic navigation lines are curved.
- o B: Hyperbolic has straight radial lines and VOR navigation lines are curved.
- o C: There is no difference between VOR and Hyperbolic navigation.

678: (Q260) What is the sniffer used for?

- A: To detect smoke in avionics compartment.
- o B: To detect fire in the avionics compartment.
- o C: To detect smoke on the flight deck.

679: (Q658) A flux valve senses the changes in orientation of the horizontal component of the earth's magnetic field. 1. The flux valve is made of a pair of soft iron bars. 2. The primary coils are fed AC voltage (usually 487.5 Hz). 3. The information can be used by a 'flux gate' compass or a directional gyro. 4. The flux gate valve casing is dependent on the aircraft three inertial axis. 5. The accuracy

on the value of the magnetic field indication is less than 0.5 %. Which of the following combinations contains all of the correct statements?

- A: 2, 3, 5.
- o B: 1, 4, 5.
- o C: 1, 3, 4, 5.

680: (Q151) How many satellites are required for GNSS?

- A: 4
- o B: 6 (90° apart)
- o C: 8

681: (Q564) Pressure measured from atmospheric pressure is called....

- A: gauge pressure.
- o B: relative pressure.
- o C: absolute pressure.

682: (Q500) ARINC 629 current mode couplers are

- o A: resistive.
- o B: capacitive.
- C: inductive.

683: (Q59) Which system is used to determine precise points located on an aircraft?

- o A: frame stations, vertical lines and lateral lines.
- B: frame stations, water lines and buttock lines.
- o C: longitudinal, vertical and lateral lines.

684: (Q472) TCAS 2 (Traffic Collision Avoidance System) uses for its operation:

- A: both the replies from the transponders of other aircraft and the ground-based radar echoes.
- o B: only the echoes from the ground air traffic control radar system.
- o C: only the replies from the transponders of other aircraft.

685: (Q544) What will an extended fowler flap increase?

- o A: Wing area.
- o B: Wing area and aspect ratio.
- C: Wing area and camber.

686: (Q13) Which control surfaces provide directional and pitch control?

- A: ruddervators.
- o B: tailerons.
- o C: elevons

687: (Q12) On an aircraft fitted with elevons in normal flight. What happens to the Elevons when the control column is moved forward?

- o A: remain stationary.
- B: both move down.
- o C: both move up.

688: (Q264) Which of the following areas in an aircraft would only have a smoke detection system and no extinguishing system?

- A: Avionics bay.
- o B: Engines.
- o C: Cargo bay.

689: (Q770) What will be shown when the fault tolerant system has a fault but has not generated a caution or a warning on the flight deck?

- o A: A scheduled fault message.
- B: A maintenance memo.
- o C: A specific status message.

690: (Q211) During normal stages of flight, the engine bleed air source comes from:

- o A: The high pressure stage of the compressor.
- o B: Ram air.
- C: The low pressure stage of the compressor.

691: (Q314) What is the purpose of a shuttle valve?

- o A: maintaining fluid press when the emergency system fails.
- o B: preventing fluid loss from a leaking jack.
- C: change over from main to alternate system in the case of failure.

692: (Q660) The Ground Proximity Warning systems mode 2 is activated when

- o A: An excessive height loss is experienced after take-off during go-around.
- B: The aircraft is flying into rising terrain.
- o C: The barometric descent rate is excessive with respect to the aircraft height above the terrain.

693: (Q35) What limits the maximum forward speed of a helicopter?

- o A: engine power.
- B: retreating blade stall and the forward speed of the advancing blade.
- o C: the shape of the fuselage.

694: (Q745) What is the primary control interface between the IFES (In Flight Entertainment System) and cabin and maintenance crews?

- o A: The IFES SC (system controller).
- o B: The IFES AMCU (Advanced Master Control Unit).
- C: The IFES CP (Crew Panel).

695: (Q411) An aircraft has yaw damping included in its auto stabilisation system. An essential requirement of such system is:

- o A: series connected servo motors.
- B: a three axis autopilot system.
- o C: INS inputs to the CADC.

696: (Q141) The period of validity of the navigational database is:

- o A: 91 days.
- o B: 1 month.
- C: 28 days.

697: (Q705) Information from a sensor to a display is provided electronically to the processing unit, commonly called a.....

- A: symbol generator.
- o B: video graphics card.
- o C: video card.

698: (Q161) Which is the most efficient way of charging a battery?

- A: Fast
- o B: Both slow and fast are equally efficient
- o C: Slow

699: (Q221) Where is the water separator located?

- A: Downstream of the compressor.
- o B: Downstream of anti ice valve.
- o C: Downstream of the turbine.

700: (Q522) The capacity of the emergency batteries are capable of providing emergency lighting for a period of at least ...

- o A: 1 minute.
- o B: 1 hour.
- C: 10 minutes.

701: (Q148) If one FMS fails in a dual system

- A: FMS display transfers data automatically from serviceable computer.
- o B: system operation will not be affected.
- o C: FMS CDU on fail side goes blank.

702: (Q20) The purpose of a spring tab is to....

- o A: provide feel back in a control system.
- o B: provide a constant load resistance to surface deflection at all speeds.
- C: provide a reduction in the pilot's effort to move the controls against high air loads.

703: (Q655) A slaved directional gyro derives it's directional signal from:

- o A: The air data computer.
- o B: A direct reading magnetic compass.
- C: The flux valve.

704: (Q555) What eliminates Dutch roll?

- o A: The differential ailerons.
- B: The yaw damper.
- o C: The Dutch Roll damper.

705: (Q510) In which frequency band does the Microwave Landing System (MLS) operate?

- o A: VHF
- o B: UHF
- C: SHF

706: (Q545) The type of flap that extends rearward from the trailing edge as it is lowered is....

- A: a Fowler flap.
- o B: a Zap flap.
- o C: a Kreuger flap.

707: (Q761) Switching from avionics to flight operation domain is the OIS (On board Information System) is done by....

- o A: OIT control device.
- o B: OIT Terminal processor unit.
- C: OIT side switches.

708: (Q143) What is an FMC?

- o A: An autopilot/flight director system.
- o B: A flight management inertial reference system.
- C: A flight management computer.

709: (Q698) Angle of attack may be sensed by means of ...(1) ...mounted ...(2)...

- o A: (1) a stick pusher - (2) adjacent to the flying controls.
- B: (1) a hinged vane sensor - (2) on the wing leading edge.
- o C: (1) a conical slotted probe - (2) on the wing leading edge.

710: (Q152) The space segment of GPS consists of a minimum of....

- o A: 21 satellites.
- B: 24 satellites.
- o C: 27 satellites.

711: (Q238) A cabin humidifier is operated....

- o A: on the ground.
- B: at high altitudes.
- o C: at low altitudes.

712: (Q403) When being engaged, and without selecting a particular mode, an automatic pilot enables....

- A: aeroplane stabilisation with attitude hold.
- o B: all aeroplane piloting and guidance functions except maintaining radio-navigation course lines.
- o C: a constant speed on track, wings horizontal.

713: (Q340) In a hydraulic landing gear system, of which component does a sequence valve ensure proper timing?

- A: landing gear doors.
- o B: main gear down locks.
- o C: main gear safety switches (proximity switches).

714: (Q497) What is the Speed of an ARINC 429 system?

- o A: 2.3 - 23 Mbits/s
- B: 100 kbits/s
- o C: 2 - 6 Gbits/s.

715: (Q598) Machmeter readings are subject to:

- o A: instrument and compressibility errors.
- B: instrument and pressure errors.
- o C: compressibility and position errors.

716: (Q400) With airspeed hold engaged, Flight Director engaged, a down command means your speed....

- o A: has increased.
- o B: keeps the same.
- C: has decreased.

717: (Q262) In a pneumatic fire sensor, what triggers the fire warning?

- o A: The difference pressure between static air pressure and expended air pressure.
- B: The pressure increase caused by the release of gas from the absorption material acting on a pressure switch.
- o C: The temperature of the gas inside the steel tubing acting on a temperature switch.

718: (Q610) While carrying out a leak check of the altimeter, if the static is leaking, the VSI would:

- o A: not be affected.
- B: indicate decent.
- o C: indicate climb.

719: (Q69) The relationship between the electric field and the magnetic field in a dipole or monopole antenna are....

- o A: in phase.
- B: out of phase by 90°.
- o C: in phase on a monopole and out of phase in a dipole.

720: (Q355) Oxygen for the flight crew of commercial aircraft comes in which form?

- o A: Liquid oxygen.
- o B: Chemical oxygen generators.
- C: Gaseous oxygen.

721: (Q322) When is a 'hot rod' type of ice detector switched on?

- o A: when in the air.
- o B: all the time.
- C: when selected by the crew.

722: (Q233) How is in pressurized aircraft, temperature controlling mainly achieved?

- o A: Adding heat to the pressurising air.
- B: Adding hot bleed air to the conditioned air.
- o C: Varying cabin pressure.

723: (Q652) The indication of the directional gyro as an on-board instrument are valid only for a short period of time. The causes of this inaccuracy are: 1. The earth's rotation. 2. The longitudinal acceleration. 3. The aircraft's motion over the surface of the earth. 4. The mechanical defects of the gyro. 5. The gyro's weight. 6. The gimbal mount of the gyro rings. The combination of correct statements is:

- o A: 1, 3, 4.
- B: 1, 3, 4, 6.
- o C: 2, 5, 6.

724: (Q361) Is it possible to regulate the amount of oxygen from a chemical oxygen generator?

- o A: Yes.
- B: No.
- o C: Only the crew.

725: (Q480) Weather Radar returns show areas of precipitation in the following colors:

- o A: Green, Orange, Yellow and Red.
- B: Green, Yellow, Red and Magenta.
- o C: Green, Magenta, Blue and Red.

726: (Q146) In the FMS vertical navigation (VNAV) climb mode the throttles are used for

- o A: controlling to a maximum thrust.
- B: maintaining a computed EPR.
- o C: correction for minor speed deviations.

727: (Q471) On a TCAS2 (Traffic Collision Avoidance System) the preventive 'resolution advisory' (RA)....

- A: suggests action to be taken to avoid a conflict.
- o B: advises the pilot to modify effectively the vertical speed of his aircraft.
- o C: advises the pilot to modify the speed of his aircraft.

728: (Q293) To decrease the amount of unusable fuel, what is fitted to the engine feed manifold?

- o A: NACA duct.
- B: drain check valve.
- o C: float valve.

729: (Q413) A Stability Augmentation System (SAS) is a rate damping system that will:

- o A: Stop unwanted rate of motion from developing.
- B: All of the answers.
- o C: Gives good control and handling characteristics.

730: (Q33) What is autorotation?

- o A: loss off directional control.
- o B: spinning of the helicopter fuselage due to the loss of anti-torque.
- C: descent of the helicopter with power off.

731: (Q467) Secondary Surveillance Radar is a form of .(1)..radar with .(2)..type emissions operating in the .(3)..band.

- o A: (1) primary - (2) pulse - (3) SHF
- o B: (1) secondary - (2) FM - (3) SHF
- C: (1) secondary - (2) pulse - (3) UHF

732: (Q597) If the static source becomes blocked with ice and the aircraft descends rapidly, the Machmeter will:

o A: not be subject to any errors because of the dual capsule. not be subject to any errors because of the dual capsule.

- B: over-read. over-read.
- o C: under-read. under-read.

733: (Q28) Above the critical Mach number, the drag coefficient

- o A: decreases.
- o B: remains the same.
- C: increases.

734: (Q416) Automatic trim is used to....

- A: maintain level flight.
- o B: prevent loads on the elevator trims.
- o C: allow full authority to be regained by the aileron.

735: (Q738) 'Some LRMs (Line Replaceable Modules) from the Integrated Modular Avionics communicate with each other through the ADCN (Avionics Data Communication Network) by the means of communication technology developed from a non-aeronautical standard.' This technology is called....

- A: AFDX (Avionics Full Duplex Switched Ethernet).
- o B: Controller Pilot Data Link communications (CPDLC).
- o C: Automatic Dependent Surveillance Broadcast (ADS-B).

736: (Q230) What needs to be done to the bypass valve to lower the pack outlet temperature?

- o A: Remain the same.
- B: Closed.
- o C: Opened.

737: (Q90) The distance between the transmitter and the nearest point at which refracted waves return to earth is referred to as the

- o A: return distance.
- o B: reception distance.
- C: skip distance.

738: (Q261) What type of smoke detector contains radioactive material?

- A: Ionizing smoke detectors.
- o B: Carbon monoxide detectors.
- o C: Photo-electric smoke detectors.

739: (Q4) When inner and outer ailerons are mounted, outer ailerons are used:

- o A: at high speeds.
- B: at low speeds.
- o C: during take-off only.

740: (Q248) The outflow of air from the cabin is regulated by ....

- A: outflow valves.
- o B: vent valve.
- o C: trim valve.

741: (Q302) In an open-centre hydraulic system, selector valves are positioned ...

- A: in series.
- o B: either in series or parallel depending on the system design.
- o C: in parallel.

742: (Q36) With an increase in its angle of attack, what happens to the drag acting on a rotor blade?

- A: increases.
- o B: decreases.
- o C: remains constant.

743: (Q89) For hf-radio communications covering long distances, what is the most important layer of the ionosphere?

- o A: D
- o B: C
- C: F

744: (Q713) Which system provides airline flight, maintenance, and cabin crews with instantaneous access to operational manuals, procedures and navigation charts?

- o A: FMS (Flight Management System).
- B: ELS (Electronic Library System).
- o C: OMS (Onboard Maintenance System).

745: (Q365) Which indication of a used chemical oxygen generator is provided?

- o A: No indication, only by weighing the oxygen generator the status can be determined.
- B: A change of colour of a band of thermal paint around the case.
- o C: The pressure indicator will be in the red zone.

746: (Q654) The purpose of the flux-valve is:

- o A: To measure the strength of the earth's magnetic field.
- o B: To provide flux for the automatic slaving system.
- C: To sense the direction of the earth's magnetic field relative to the airplane.

747: (Q441) During flare mode autothrottle will

- o A: disconnect autothrottle.
- B: retard throttles to idle.
- o C: select reverse thrust.

748: (Q669) When accelerating on an easterly heading in the northern hemisphere, the magnet system of a direct reading compass will:

- o A: Turn anti-clockwise, indicating an apparent turn towards South.
- o B: Turn clockwise, indicating an apparent turn towards North.
- C: Turn anti-clockwise, indicating an apparent turn towards North.

749: (Q569) Pitot pressure is a combination of:

- A: static pressure and dynamic pressure.
- o B: static pressure and position error.
- o C: dynamic pressure minus pitot pressure.

750: (Q450) Overshoot or go-around mode can be initiated....

- o A: at any time.
- o B: only when autopilot is engaged.
- C: below 2000 feet radio altitude.

751: (Q351) What is the advantage that stress sensors have over other air/ground sensing systems?

- o A: Easier to replace.
- B: Can measure aircraft weight.
- o C: More reliable.

752: (Q617) A remote reading thermometer depends upon....to indicate changes in temperature.

- A: change of electrical resistance with temperature.
- o B: change of electrical capacitance with change in temperature.
- o C: change of electrical resistance of the two metals.

753: (Q767) Recording capability of aircraft parameters is part of the ...

- A: Avionics Domain.
- o B: Communication & Cabin Domain.
- o C: Flight Operations Domain.

754: (Q739) This is a.... (See the figure)



- o A: RJ61 connector.

- o B: RJ12 connector.
- C: RJ45 connector.

755: (Q203) Lights fitted with a dual filament are used as:

- o A: Landing light and runway turn-off light.
- o B: Runway turn-off light and engine scan light.
- C: Landing light and taxi light.

756: (Q700) An engine vibration indicator receives a signal from different sensors (accelerometers). It indicates the:

- o A: Acceleration measured by the sensors, expressed in g.
- B: Vibration amplitude at a given frequency.
- o C: Vibration frequency expressed in Hz.

757: (Q290) When will a fuel boost pump bypass valve open?

- o A: when the engine driven pump fails.
- B: when the booster pump fails.
- o C: when both the engine driven and booster pump fail.

758: (Q531) How can adverse yaw when rolling about the longitudinal axis may be prevented?

- A: Differential ailerons.
- o B: Equal deflection lateral control surfaces.
- o C: A smaller fin.

759: (Q331) What must be done when testing windshield wipers?

- o A: operate them on a dry windshield.
- B: use a continuous flow of water on the windshield.
- o C: lift the wipers away from the windshield.

760: (Q678) Identify the correct statement (See the figure)

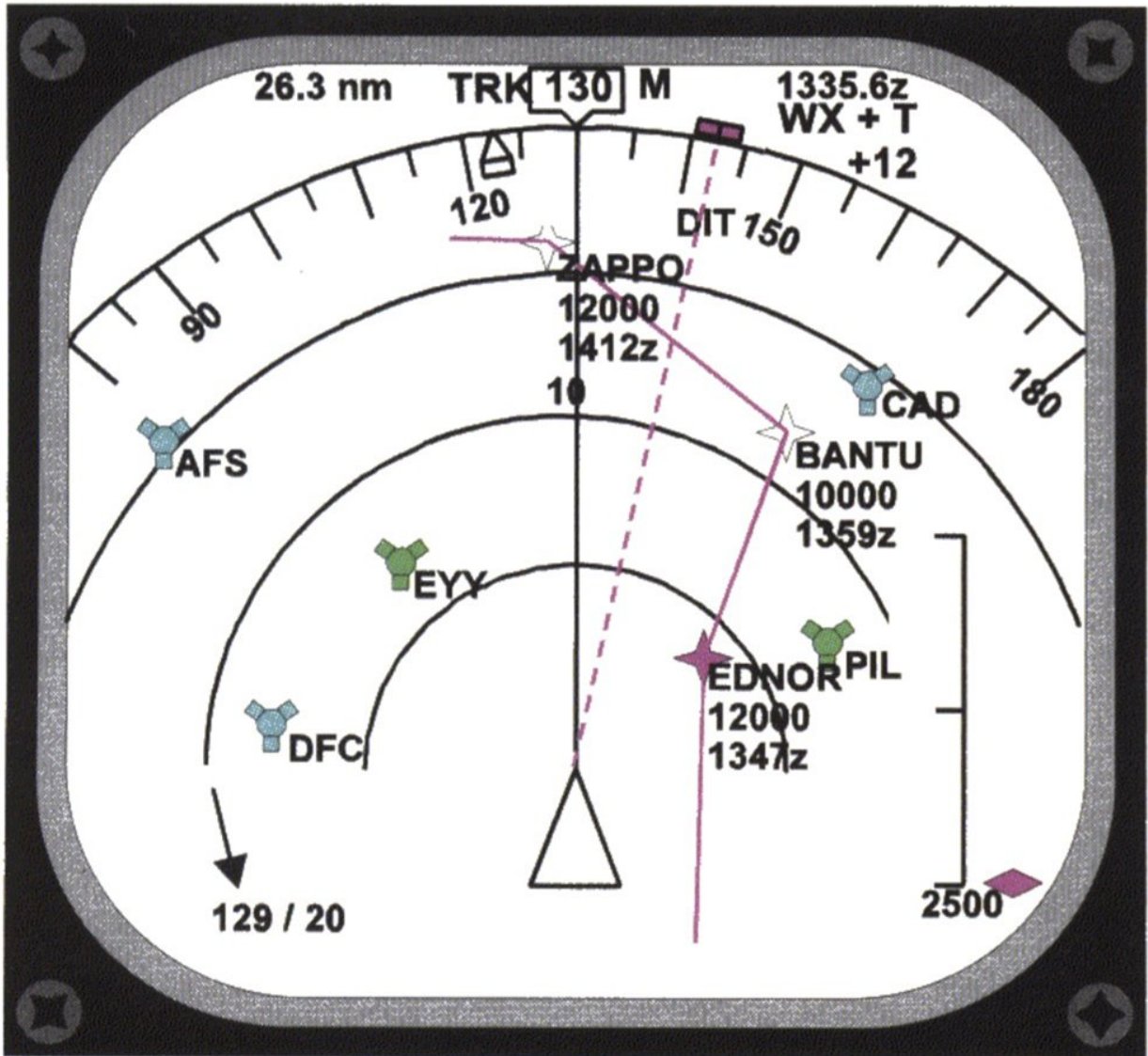

- A: The aircraft is closing the localiser from the right, heading 130°M and is approaching the glide path from above.
  - o B: The aircraft's track is 165°M.
  - o C: When established on the localiser the inbound heading will be 165°M.

761: (Q684) With an EFIS flight director using IRS guidance, reference north can be:

- o A: true north between 73°N and 65°S and magnetic north above these latitudes.
  - B: magnetic north between 73°N and 65°S and true north above these latitudes.
  - o C: magnetic north only.

762: (Q716) Direct texts entry for airport directory or word searches on the Electronic Library System is done by ...

- o A: the scratch pad on the CDU.
- o B: a keyboard underneath the active-matrix liquid display.
- C: a soft keyboard function, displayed on the liquid display screen.

763: (Q325) An ice deposit formed when liquid water flows over the airframe before freezing, and which is dense, tough and sticks closely to the surface is called ...

- o A: hoar frost.
- B: glaze ice.
- o C: rime ice.

764: (Q337) What is a stripe or mark extending from the rim of a wheel onto the tire?

- o A: Indicates the tire is a high-pressure type.
- B: A creep mark.
- o C: A balance mark.

765: (Q208) To ensure correct operation of the emergency lighting system, what must be done at specific maintenance intervals?

- o A: Recharge the battery packs.
- o B: Replace all emergency light bulbs.
- C: Replace the battery pack.

766: (Q632) The compensator in a fuel tank measures....

- o A: specific gravity of fuel.
- o B: fuel quantity.
- C: capacitance of fuel transmitter.

767: (Q280) What indicates the yellow disk of a fire bottle (if installed) when it is ruptured?

- o A: That the fire bottle is due for inspection.
- B: That the bottle has been fired.
- o C: That the pressure in the fire bottle was too high.

768: (Q147) To know the valid data base on the FMS

- o A: call up the relevant current status.
- o B: perform a BITE check.
- C: call up the relevant page on the CDU.

769: (Q96) Uniform capacitance throughout the length of the line is an advantage of which of the following transmission lines?

- A: Shielded pair.
- o B: Twisted pair.
- o C: Coaxial line.

770: (Q236) The temperature within the cabin of the aircraft is normally maintained at ....

- o A: 12 °C to 18 °C.
- B: 21 °C to 27 °C.
- o C: 20 °C to 24 °C.

771: (Q671) The flight data recorders must preserve the required data of the last:

- o A: 48 hours of operation.
- o B: 30 minutes of operation.
- C: 25 hours of operation.

772: (Q412) A triplex system loses one channel, the pilot....

- A: can continue with autoland.
- o B: can use auto approach only.
- o C: must make a full manual approach and land.

773: (Q723) Maintenance Information at an out-station can be read from the....

- o A: Electronic library system.
- B: CDU (Control Display Unit).
- o C: FMS (Flight Management system).

774: (Q373) How are the gyroscopes in a pneumatic gyro instrument system on an aircraft at high altitude driven?

- A: By air pump suction.
- o B: By bleed air pressure.
- o C: By ram air.

775: (Q501) ARINC 629 data bus is

- A: one bus, bi-directional data flow.
- o B: two buses, unidirectional.
- o C: two buses, bi-directional data flow.

776: (Q174) If the over-speed protection circuit in a CSD (Constant Speed Drive) has activated, reset is....

- o A: possible during Line Maintenance.
- B: only possible in the workshop.
- o C: possible from the flight deck.

777: (Q508) Which one of the following correctly lists the major ground based components of a Microwave Landing System (MLS)?

- o A: Separate azimuth and elevation transmitters, outer and middle marker beacons.
- B: Separate azimuth and elevation transmitters, DME facility.
- o C: Combined azimuth and elevation transmitter, marker beacons.

778: (Q566) In a mechanical oil pressure gauge the sensing element is:

- o A: a helical bimetallic spring.
- B: a bourdon tube.
- o C: a liquid capillary.